

# Window Friction Hinges

## Standard and Heavy Duty, Egress/Easy Clean, Side Hung

- **Size and weight parameters are to be strictly observed**
- Passed endurance assessment by the British Board Agreement
- Negates the use of standard hinges
- Waterproof lubricant added to each pivot point during manufacture
- Slotted fixing holes in the base channel and sash bar, with final fixing holes in each component
- Stacking height 13 mm on standard and 14 mm heavy duty (17/18 mm available to order, subject to quantity)
- Suitable for timber, PVCu and aluminium windows
- **Friction hinges should always be fixed with end-cap abutting the corner of the window frame (see diagram, right)**
- Friction hinge mounting faces must be flat, parallel and provide the correct cavity clearance, 13/14 mm or 17/18 mm (-0 mm +1 mm)
- Centre line of both vent and frame should be coincidental and parallel
- After installation, the friction screw should be adjusted to obtain the desired resistance
- All windows hardware will require regular inspection, cleaning and maintenance in order to operate in the manner for which they have been designed
- 10 year performance guarantee
- Heavy duty tested to BS 213 - minimum 95 mm cleaning gap

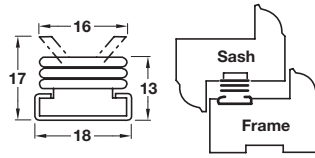

### **A** Standard duty Egress/Easy clean friction hinge, for side hung windows

- Unhanded
- Allows specifiers and fabricators to conform to BS 5588 Part 1: 1990 and current UK building regulations
- Hinge quickly provides the minimum required opening of 550 mm wide x 850 mm high with simple one-handed operation in accordance with BS 5588
- Easy Clean is operated by the simple action of opening the vent to its fullest extent at 90°, releases both top and bottom catches. In this position the window is safe, and can be eased along the track to facilitate cleaning the outside face
- While cleaning, the hinge remains safe and stable due to a design feature that locks the two sliding mechanisms
- An integral riser pad makes closing much easier
- Window labels providing operating instructions are supplied
- One size only
- Stay parts: Ferritic stainless steel grade 430
- Friction slide: Glass-filled nylon
- Adjustment screws: Brass

**Item A.**  
Text repositioned

Size	Max. vent width	Max. vent height	Max. vent weight	Opening angle	Cat. No.
406 mm (16")	700 mm	1300 mm	26 kg	90°	911.59.125

Order qty: 1 pair

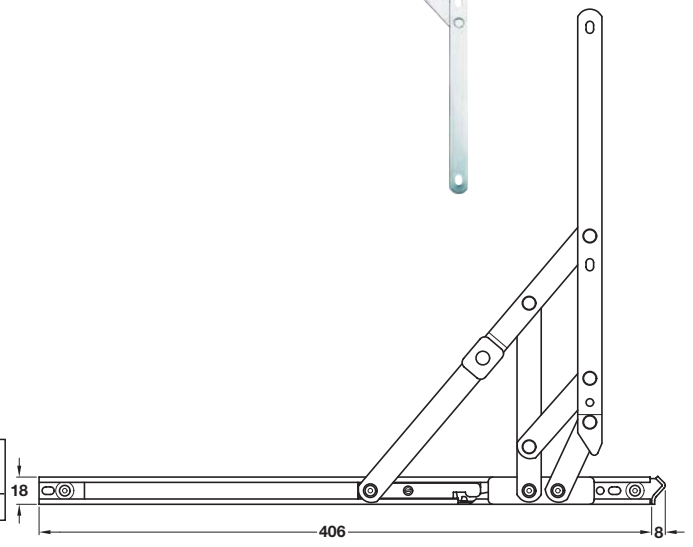

7

### **B** Loadpro heavy duty Egress/Easy clean friction hinge, for side hung windows

- Unhanded
- Allows specifiers and fabricators to conform to BS 5588 Part 1: 1990 and current UK building regulations
- Hinge quickly provides the minimum required opening of 550 mm wide x 850 mm high with simple one-handed operation in accordance with BS 5588
- Easy Clean is operated by the simple action of opening the vent to its fullest extent at 90°, releases both top and bottom catches. In this position the window is safe, and can be eased along the track to facilitate cleaning the outside face
- While cleaning, the hinge remains safe and stable due to a design feature that locks the two sliding mechanisms
- An integral riser pad makes closing much easier
- Window labels providing operating instructions are supplied
- One size only
- Stay parts: Ferritic stainless steel grade 430
- Friction slide: Glass-filled nylon
- Adjustment screws: Brass

Size	Max. vent width	Max. vent height	Max. vent weight	Opening angle	Cat. No.
406 mm (16")	800 mm	1250 mm	35kg	90°	911.59.150

Order qty: 1 pair

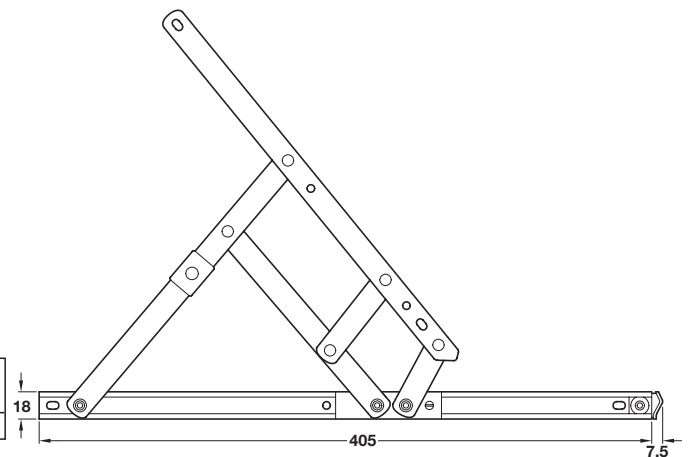

08.10.08/1