

Fittings to Aid Disabled Persons

Rising and Falling Butt Hinges and Damper Unit

Regular lubrication required unless marked maintenance free
All fixings for timber included.



A Stainless steel rising butt hinge

- Handed - specify clockwise or anti clockwise closing
- Maximum adjusted door weight **60 kg**
- Minimum door thickness **29 mm**
- Concealed cams when closed
- Door closes on release
- Fixing screws included
- Rises 16 mm at 180°
- Grade 304 stainless steel
- **Note:** Only 2 hinges per door leaf are required

Length x width	100 x 77mm
Closing direction	Satin
Clockwise	980.15.000
Anti-clockwise	980.15.010

Order qty: Multiples of 2 pcs

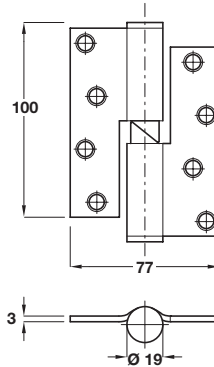

RT



Satin stainless steel finish shown
Anti-clockwise closing

B Stainless steel falling butt hinge

- Handed -specify clockwise or anti clockwise closing
- Maximum opening angle **120°**
- Maximum adjusted door weight **50 kg**
- Minimum door thickness **29 mm**
- Concealed cams when open
- Door opens on release
- Fixing screws included
- Falls 10.5 mm at 120°
- Grade 304 stainless steel
- **Note:** Only 2 hinges per door leaf are required

Length x width	100 x 77 mm
Closing direction	Satin
Clockwise	980.15.020
Anti-clockwise	980.15.030

Order qty: Multiples of 2 pcs

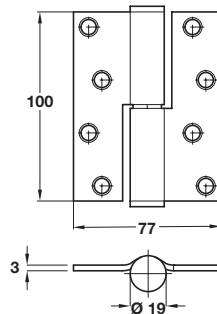

RT



Satin stainless steel finish shown
Anti-clockwise closing

C Hydraulic damper unit

- Specifically designed to control the doors closing speed when used in conjunction with rising butt hinges (item A). This is particularly appropriate if the door is very heavy.
- The damper unit fits discretely into the hinge jamb and is fully adjustable
- Dampens the closing action between 26° and 0° on 44 mm thick doors
- 2.5 x 16 mm fixing screws included
- Mild steel body. Stainless steel faceplate. Grade 304

Cat. No.	980.15.900
----------	------------

Order qty: 1 pc

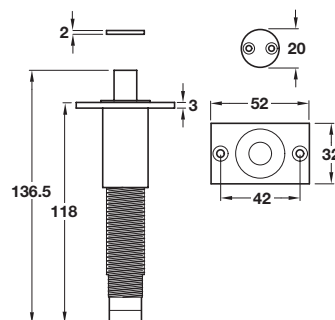

RT

