

Panic hardware maintenance

It is important that all panic and emergency exit hardware devices are inspected and maintained properly to ensure safety is maintained when exiting a building in any situation.

Once a device is fitted, regular maintenance is recommended.

Weekly:

- Make sure the exit device functions correctly
- Any fixings that have worked loose should be re-secured
- Any damaged components should be replaced
- Ensure there are no obstructions which prevent the panic unit from functioning correctly

Every three months:

- Check for wear, any visible worn components should be replaced

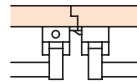
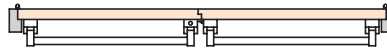
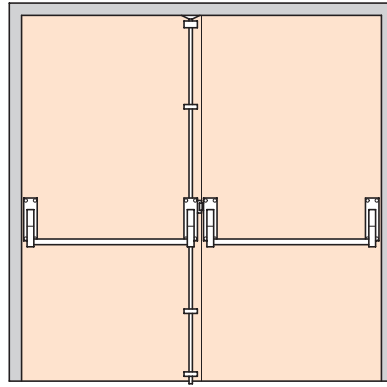

For further information on **BS EN 1125**, please refer to the Standards pages shown at the back of this catalogue



BS EN 1125:1997 A1:2001

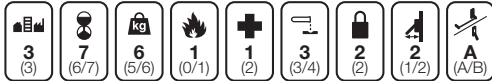

A Double panic bolt

- For double rebated outward opening doors up to max. 2400 mm high x 2440 mm wide
- One set consists of:
 - 1 x Single panic bolt, item **A** page **44**
 - 1 x Single panic latch, item **A** page **45**
 - 1 x Box keeper, item **C** page **49**
- Push bar and shoots supplied with plugs for on-site cutting
- Easy clean floor socket included
- Anti-thrust device to prevent leverage of shoots
- Shoot bolts automatically held retracted when door is in open position, and released on closing
- Suits either hand
- Exit only
- Tested and approved to BS EN 1125
- Certifire approved; certificate no. 392 60 mins for timber doors
- Fixings included, for timber doors
- Self adhesive vinyl 'Push bar to open' sign included
- Diecast aluminium and mild steel. Epoxy powder coated or plated finish*
- **Please note:**
 - We strongly recommend the use of hinge bolts or security hinges with panic hardware
- We are able to supply this product with passivate protection, larger sizes and micro-switches to order, subject to quantity
- RAL colours available to order, subject to quantity**
- For external access devices to suit, please refer to page **49**
- For Pullman catch kits, refer to page **48**
- For screw fixing versions of signage associated with panic exit devices, i.e. 'Push bar to open' and 'Fire escape keep clear' refer to pages **10** and **12**

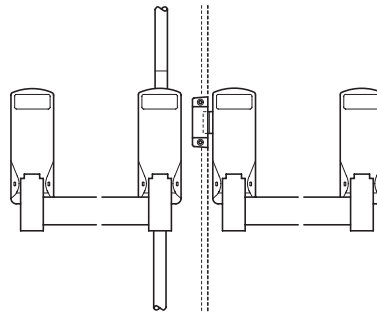

Item A.
Photo amended



Finish	Cat. No.
Silver	911.52.319
Gold	911.52.318
Satin stainless steel	911.52.310*
Polished stainless steel	911.52.311*
Polished brass	911.52.315*
RAL colours	To order**

Order qty: 1 set

12.04.10/1*