

Mortice Cylinder Locks and Latches Multipoint Locking System

All moving parts should be lightly lubricated using a light non-acidic mineral oil (eg. "3 in 1"), twice per year and surface cleaned with a soft damp cloth. The product may need to be adjusted and fixings tightened to ensure a satisfactory operation.

Multipoint lock system dimensions			
		Length with shoot bolts added	
		Minimum	Maximum
Backset 35 mm			
1810 x 16 mm	911.50.790	1740 mm	2120 mm
Backset 45 mm			
1810 x 16 mm	911.50.791	1740 mm	2120 mm

A Mortice cylinder slave unit

- **Operation:** Shoot bolt operated by lever handles. Deadlock by cylinder
- **Case:** Steel, BZP CR3 passivate, 14.5 mm thick
- **Front plate:** Square, 1 piece. Steel, BZP CR3 passivate. 2120 mm (including shoot bolts) x 16 mm wide. Front plate can be shortened by max. 130 mm top and bottom
- **Keeps:** Not included, must be ordered separately
- **Follower:** 8 mm brass. For use with standard 92 mm **unsprung** lever handles
- Accepts most europrofile cylinders
- Corrosion resistance: Plated to BS EN 1670 Grade 4
- Designed to meet the requirements of PAS 23 and PAS 24
- 10 year guarantee
- **35 or 45 mm** backset
- Fixings screws are not included
- **Order hi-security shoot bolts separately;** shown on page 34
- **Order cylinders separately;** see pages 40-50
- **Order keeps separately;** shown on page 34
- For lever handles, see below

Front plate width: 16 mm	Cat. No.
Backset 35 mm	911.50.790
Backset 45 mm	911.50.791

Order qty: 1 pc

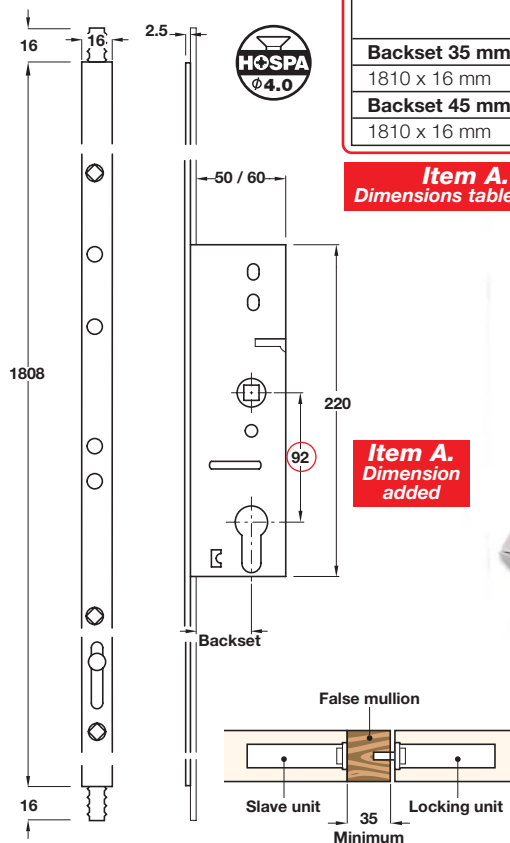

Item A.
Dimensions table added

Item A.
Dimension added



2

B Lever handles

- Designed to suit multipoint locks
- Bolt through fixings included
- Spring units are included for use with standard sprung lock cases
- 92 mm centres
- Die cast zinc alloy

Finish	Cat. No.
White	901.80.817
Polished chrome	901.80.812
PVD polished gold	901.80.815

Order qty: 1 pair

Item B.
Catalogue reverted back to read 1 pair

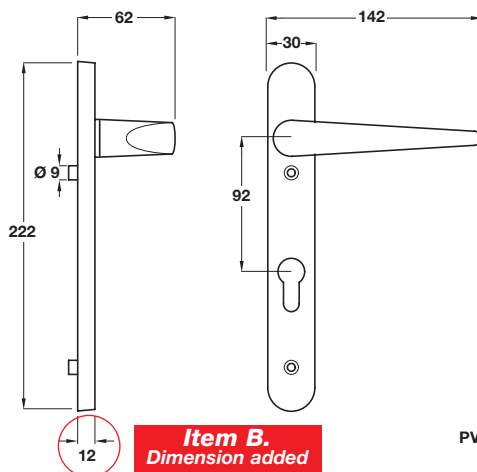

Internal handle of pair shown
(External handle has concealed fixing)

PVD polished gold finish shown

C Lever handles

- Designed to suit multipoint locks
- Bolt through fixings included
- 92 mm centres
- Die cast zinc alloy

Finish	Cat. No.
White	901.80.827
Black	901.80.823
Polished silver	901.80.829
Satin silver	901.80.826
Polished gold	901.80.825

Order qty: 1 pair

Item C.
Dimension added

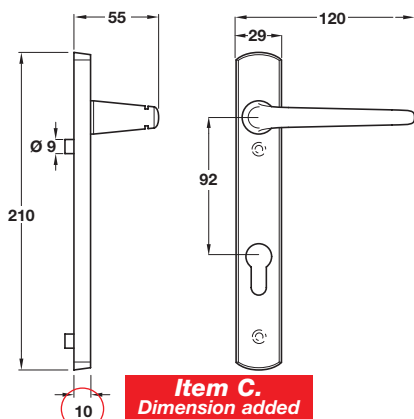

Internal handle of pair shown
(External handle has concealed fixing)

Satin silver finish shown

11.06.09/4*

TCH-A1 2008, HUK. Dimensional data not binding. We reserve the right to alter specifications without notice.