

- Application:** For unobtrusive straight sliding all-glass doors, with silver anodised or stainless steel effect finish
- Range:**

Max. door weight	80 kg
Glass thickness	8-10 mm
Max. door height	2200 mm
- Features:** Gentle, quiet running, positive fitting glass fixing for maximum safety and reliability. Track stopper with adjustable retainer. Vertical adjustment without removing the glass door. Rattle-proof bottom guide

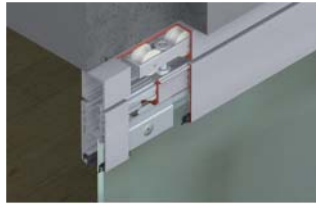

Features: Top track stopper with adjustable retention force, height-adjustable without removing door panels, cover plates in various finishes, rattle-proof bottom guide for sliding glass doors, simple assembly, can be used with HAWA-Toplock and wall joint profile and HAWA-Junior angle profile for side fixing to an adjacent wall

A Top track

With screw holes for soffit fixing. Silver anodised aluminium

Finish	Silver anodised	St. steel effect
2.0 m	940.80.200	940.80.204
2.5 m	940.80.250	940.80.254
3.0 m	940.80.300	940.80.304

Order qty: 1 pc (2.0, 2.5 or 3.0 m length)

Junior 80/GL fitting set

B Trolley hanger. Sleeve bearing mounted, high-grade polyamide tandem rollers with M10 hanger bolt and patch suspension unit for clamping glass panel

C Track stopper. For adjustable mounting in top track. Zinc alloy, black painted, housing with steel spring and rubber buffer. Adjustable retaining force

D Glass retainer profile. Length 240 mm.

Aluminium

E Cover caps, for glass retainer profile. Anthracite-grey plastic

F Fitting set, for 2 glass suspension profiles (1 horizontal profile). Set = 4 pcs.

Fixing materials and adjustment tools included

For 1 door

B Trolley hanger with suspension plate	2 pcs
C Track stopper	2 pcs
D Glass retainer profile	2 pcs
E Cover caps (set of 2 pcs)	1 set
F Fitting set (4 pcs)	1 set

Cat. No. 940.81.005

Order qty: 1 set

G Cover profile set. 2 pcs cover profile and clip-on rubber, for 1 horizontal profile. Aluminium

Finish	Silver anodised	St. steel effect
Length 1.2 m	940.41.405	940.41.408

Order qty: 1 set

H Glass fixing parts, for glass retainer profile D

Must be ordered to match glass thickness

Glass thickness	8 mm	9.5 mm	10 mm
Cat. No.	940.41.050	940.41.051	940.41.052

Order qty: 1 set (8 pcs) (1 set required per panel)

I Sliders for glass. Self adhesive - press on. Transparent impact resistant PVC

For glass thickness	Cat. No.
8 mm	940.40.033
10 mm	940.40.034

Order qty: 1 pack (6 pcs) (1 pack required per panel)

J Channel. Pre-drilled for countersunk screws. Anodised aluminium

Length	2.5 m	3.5 m
Cat. No.	940.41.250	940.41.350

Order qty: 1 length

K Single floor guide, glass

1 sliding 8/10 mm glass panel. Screw fixing, surface mounted. Rattleproof, grey plastic

Cat. No.	940.40.032
----------	------------

Order qty: 1 pc (1 pc required per panel)

L Distance plate. To be fixed with bottom guide

Cat. No.	940.40.036
----------	------------

Order qty: 1 pc

M Bottom door stopper with buffer. Satin chrome

Cat. No.	940.40.052
----------	------------

Order qty: 1 pc

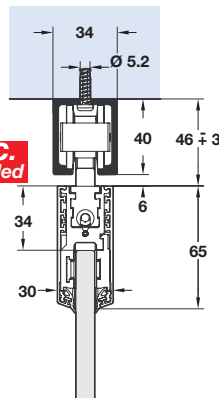

Item C.
Text added

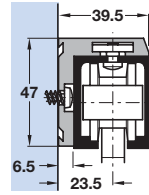

Side fixing profile for top track shown on page 89

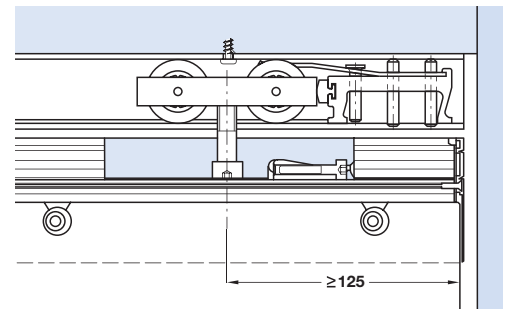

Glass cut-out detail

Only toughened safety glass (ESG) should be used

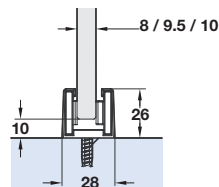
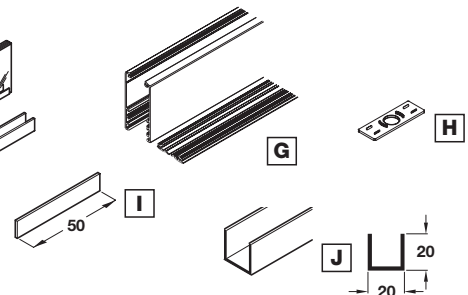
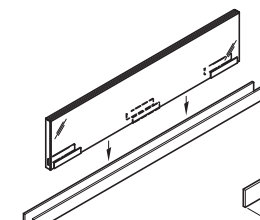
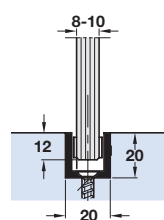
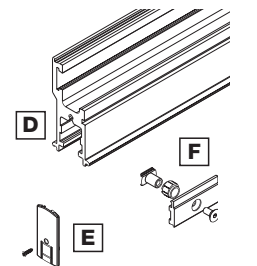
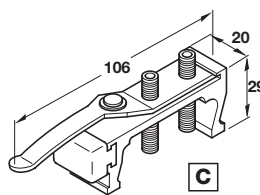
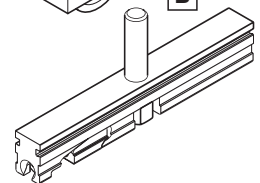
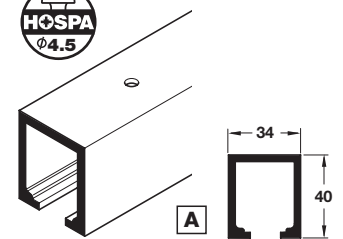
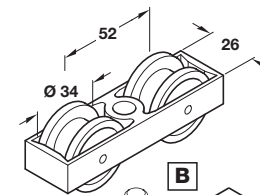

13.10.08/1*