

• **Application:** Version of Junior 40 glass system where headroom is limited. Suspension patch fitting units with decorative face plates. Normally recommended for residential or light duty commercial applications

• **Range:**

Max. door weight **40 kg**
 Glass thickness **8-12 mm**
 (toughened or laminated)
 Max. door height **2200 mm**

• Top of glass panel close to underside of top track. Height adjustment facility after installation. Choice of bottom control - either clear threshold or floor channel to provide added stability for wider doors. Choice of cover plates. Drilling jig provided for glass cut out

• **Note:** Satin stainless steel effect finish also available - information on request

• **Tracks, channels and bottom guides are not included in the fitting set and must be ordered separately**

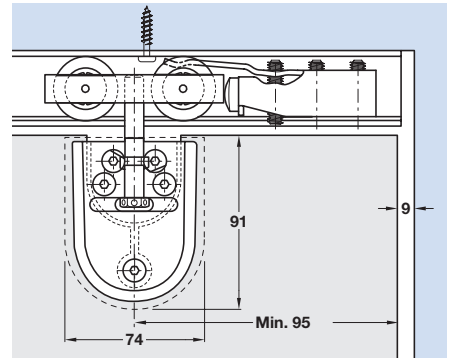

• **For ancillary door fittings, locks, handles, seals, see pages 80-87**

A Junior 40 single top track

With screw holes. Silver anodised aluminium

Length	2.0 m	3.0 m
Cat. No.	940.40.200	940.40.300

Order qty: 1 pc (2.0 or 3.0 m length)

Junior 40/GP fitting set

B Trolley hanger. Comprises trolley with M8 suspension bolt and patch suspension unit for clamping glass panel

C Track stopper. For adjustable mounting in top track. Zinc alloy housing with steel spring and rubber buffer. Adjustable retaining force

D Rubber buffer. Screw fixing

E Glass panel drilling jig. For patch assembly. To drill correct aperture in glass door panel to fit patch assembly. With drilling bush

For 1 door	
B Trolley hanger	2 pcs
C Track stopper	2 pcs
D Rubber buffer	1 pc
E Drilling jig	1 pc
Cat. No.	940.40.000

Order qty: 1 set

D Additional rubber buffer. Screw fixing. Black.	Cat. No. 407.01.930
---	---------------------

Order qty: 1 pc

F Patch assembly cover plates

Comprises 4 plates. Plastic

Rounded plates	Cat. No.
Satin chrome	940.40.027
Polished brass	940.40.028
Stainless steel	940.40.023
Polished chrome	940.41.029

Order qty: 1 set (1 set per panel required*)

G Patch fitting. For clamping of bottom guide to glass panel	Cat. No. 940.40.026
---	---------------------

Order qty: 1 set (of 1 pc, 2 pcs required per panel)

H Bottom guide. For fitting to patch fitting, to keep glass door panel aligned correctly. Nylon pilot	Cat. No. 940.40.035
--	---------------------

Order qty: 1 pc (2 pcs required per panel)

I Channel, 24 x 24 mm Pre-drilled for countersunk screws. Anodised aluminium	Length 2.5 m 3.5 m
Cat. No.	940.81.250 940.81.350

Order qty: 1 pc (2.5 or 3.5 m length)

J Bottom door stopper with buffer. Satin chrome	Cat. No. 940.40.052
--	---------------------

Order qty: 1 pc

K Floor guide, clear threshold Heavy duty. Screw adjustable 8-12 mm. Silver anodised aluminium	Cat. No. 941.00.031
--	---------------------

Order qty: 1 pc (1 pc required per panel)

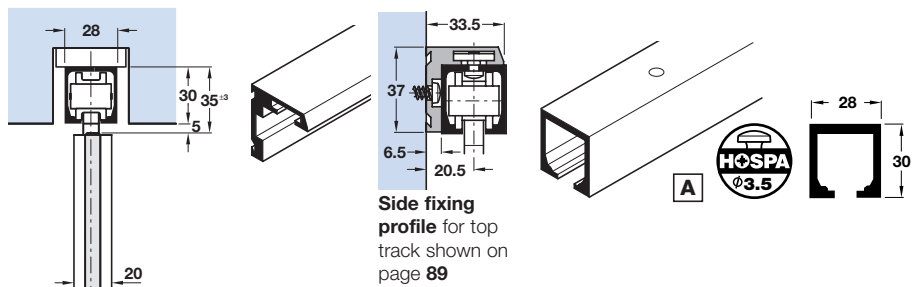

Side fixing profile for top track shown on page 89

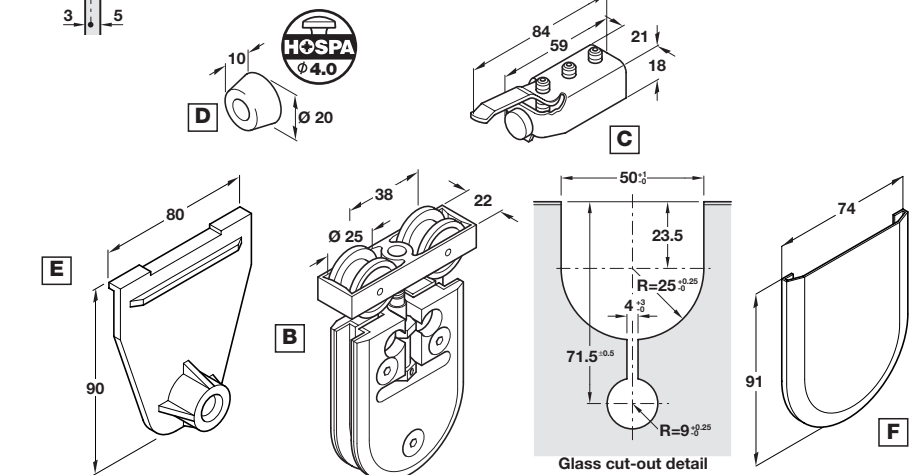

Cover plates F: *1 set per panel required if clear threshold bottom guiding is used. 2 sets per panel required if bottom guide channel is used

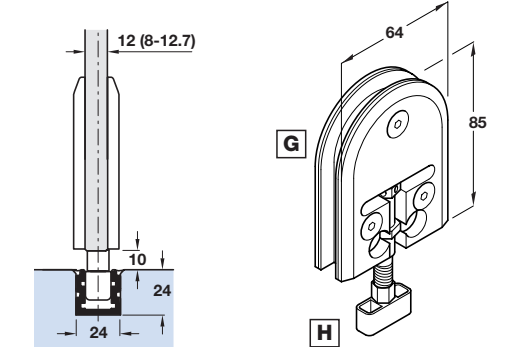

For alternative bottom guide control options - clear threshold or with floor channel, refer to page 93, items F to I

Square patches also available, shown on page 111, item F

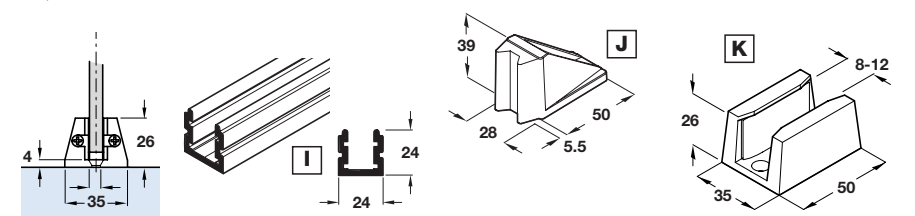

TCH-A1 2008, HUK. Dimensional data not binding. We reserve the right to alter specifications without notice.