

For HAWA-Junior 40/GL with fixed glass:

Fixed glass panel is positioned into retainer part of top track **A** shown below. No glass cut outs or additional hardware required.

Retainer profile for wall and floor fitting provides sufficient stability.

Rubber profile or silicone groove holds the glass in position and prevents humidity seeping between glass and track.

A Top track for fixed glass panel

With integrated retainer for fixed glass.
With screwholes. Aluminium. 2.0 m length

Finish	Silver anodised	St. steel effect
Cat. No.	940.40.206	940.40.211

Order qty: 1 pc (2.0 m length)

B Cover profile

For use with fixed glass top track **A**, clips into and closes retainer in walk-through area. Aluminium. 1.25 m length

Finish	Silver anodised	St. steel effect
Cat. No.	940.40.132	940.40.137

Order qty: 1 pc (1.25 m length)

C Bottom/wall profile

With screw holes. Aluminium. 3.5 m length

Finish	Silver anodised	St. steel effect
Cat. No.	940.41.535	940.41.536

Order qty: 1 pc (3.5 m length)

D Rubber profile.. 10 m roll. Black rubber.

Cat. No.	940.41.053
----------	------------

Order qty: 1 roll (10 m length)

Glass retainer **E** can be used instead of continuous floor or wall profile, if load is low:

E Bottom/wall glass retainer

Bottom/wall glass retainer. With screw holes and rubber profile. Aluminium

Finish	Silver anodised	St. steel effect
Cat. No.	940.41.054	940.41.055

Order qty: 1 pc

Wall profile, seal and centering door stops - for glass sliding doors with unprotected glass edges:

F Wall profile. Undrilled. Aluminium

Finish	2.5 m	3.5 m
Silver anodised	941.24.925	941.24.935
St. steel effect	941.24.825	941.24.835

Order qty: 1 pc (2.5 or 3.5 length)

G Rubber seal. For use with profile F. Black rubber

Length	2.5 m	3.5 m
Cat. No.	941.24.081	941.24.082

Order qty: 1 roll (2.5 or 3.5 mm length)

H Centering door stop.

For insertion into wall profile **F**. Black plastic

Cat. No.	941.24.043
----------	------------

Order qty: 1 pc

I Centering door stop. Wall fixing. Grey plastic

Cat. No.	941.24.042
----------	------------

Order qty: 1 pc (2 pcs required per panel)

J Rubber profile, black

For vertical glass edge protection - recommended for glass doors that can strike against one another. Self adhesive. For 8/10 mm glass thickness

Length	Cat. No.
5.0 m	404.95.321

Order qty: 1 roll (5.0 m length)

K Vertical seal set. For gaps between sliding and fixed glass panels. Anodised aluminium, rubber insert

Finish	2.5 m	3.5 m
Silver anodised	940.41.825	940.41.835
St. steel effect	940.41.826	940.41.836

Order qty: 1 set (2.5 or 3.5 m lengths)

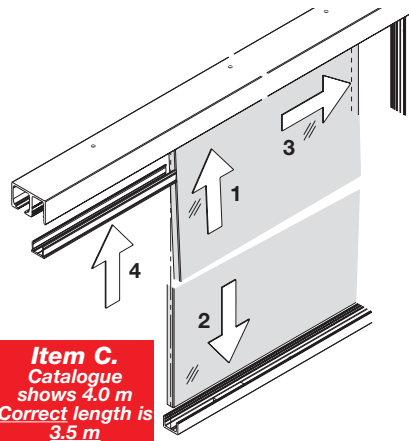

Item C.
Catalogue shows 4.0 m
Correct length is 3.5 m

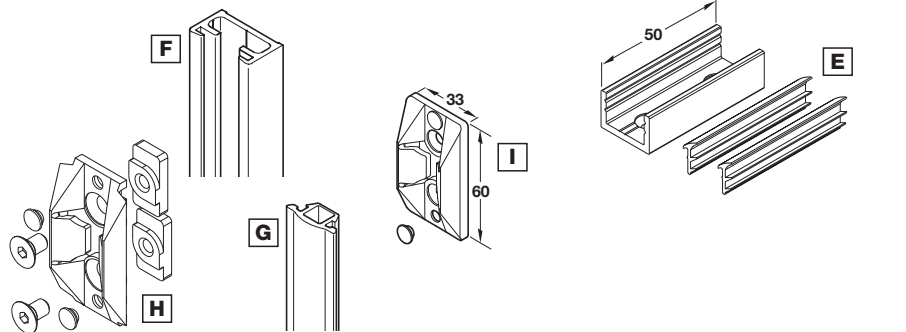
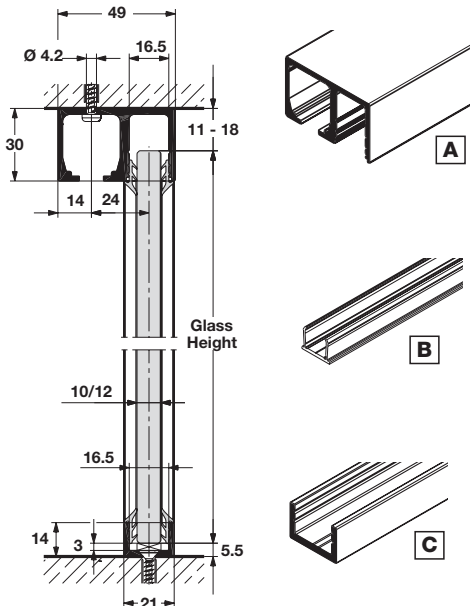
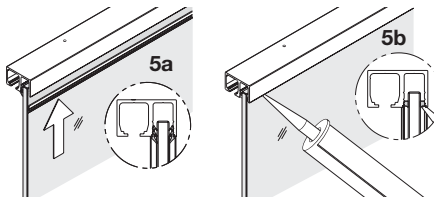

Longer lengths of rubber profile available, transparent version also available

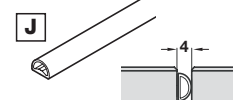

Easy fitting of fixed glass panel:

1. Slide glass into retainer part of top track **A**
2. Position the glass on the spacing block in the bottom profile **C** and/or
3. Slide sideways into wall profile **C**
4. Clip cover profile **B** into retainer part of top track **A** for walk-through area
5. Seal fixed glass with either rubber profile **D** or silicone provided by customer

