

Fittings for Straight Sliding Timber Cabinet Doors

Häfele System 9 Infront

- **Application:** Straight sliding top hung inset cupboard doors, for domestic or commercial furniture
- **Range**
Max. door weight **50 or 80 kg**
Door thickness **19 to 32 mm**
- **System 9 fitting set for 2 doors** comprises fittings **C, D or E** and **F**
- Fixing materials are included in the sets
- **Tracks and profiles are not included in the fitting sets and must be ordered separately**
- **Note:** For double doors more than 19 mm thick use two single top tracks instead of double track
- **For ancillary door hardware i.e. locks, handles and bolts refer to page 19**

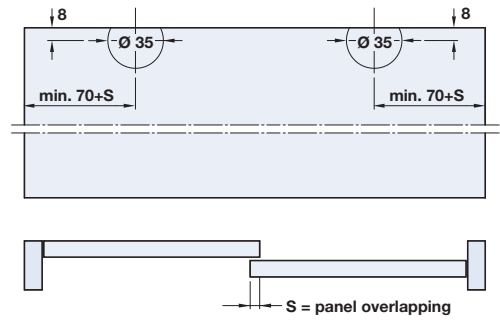
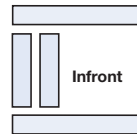

A Double top track

Pre-drilled for screw mounting. Silver anodised aluminium

Length	Cat. No.
3.0 m	401.18.930

Order qty: 1 pc

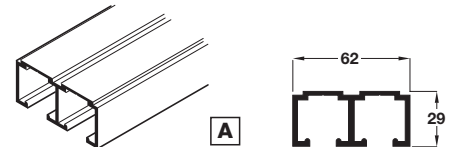
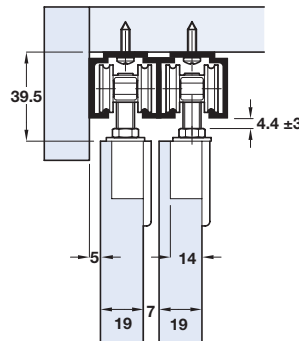

B Single top track

Pre-drilled for screw mounting. Silver anodised aluminium

Length	Cat. No.
3.0 m	401.17.930

Order qty: 1 pc

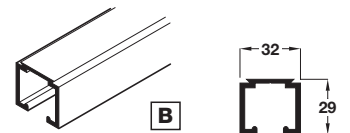
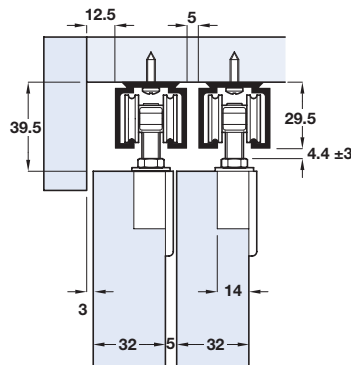

Häfele System 9 Infront fitting set

C Track stopper. For top track, reversible buffer. Adjustable retaining force. Black plastic

D Trolley hanger, for inner or outer doors

For door weights up to **50 kg**

Nickel plated zinc alloy with **two** ball bearing mounted nylon rollers. Screw fixing, adjustable

E Trolley hanger, for inner or outer doors

For door weights up to **80 kg**

Nickel plated zinc alloy with **four** ball bearing mounted nylon rollers. Screw fixing, adjustable

F Bottom guide. Press-fit. Nickel plated zinc alloy

For 1 door	
C Track stopper	2 pcs
D/E Trolley hanger	2 pcs
F Bottom guide	1 pc
Door weights	Cat. No.
Up to 50 kg	401.19.000
Up to 80 kg	401.19.001

Order qty: 1 set

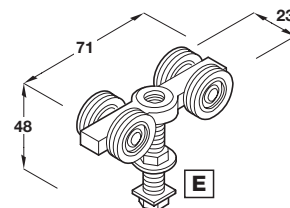
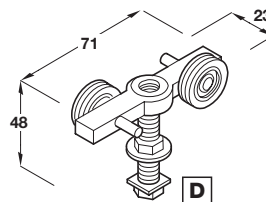
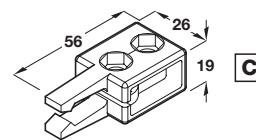

G Bottom guide profile

Off-white nylon

Length	Cat. No.
2.0 m	401.22.720

Order qty: 1 pc (2.0 m length)

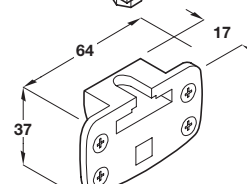
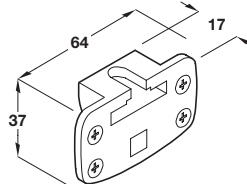

F Additional bottom guide

Cat. No.	401.20.010
----------	------------

Order qty: 1 pc

