



Stainless Steel Grade 304:

Stainless steel to EN standard No. 1.4301
ASTM/AISI 304. 18% chromium 8% nickel

Spindle type	Compatibility rating
Plain spindle	★
Piercing spindle	★★
Slotted spindle	★★★
Stabil spindle	★★★★
See page 64 for details	★★★★★

For full explanation see page 2

For all StarTec Commercial lever handles:

Drill two holes \varnothing 8 mm at 38 mm centres, to a minimum depth of 8 mm, and one \varnothing 22 mm hole to a depth of 2 mm

DIN EN 1906 - PfB

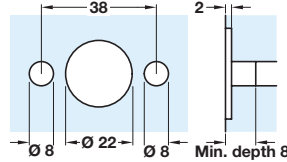

Satin stainless steel



StarTec
Commercial

A CHASE shaped lever handles

- Pair of lever handles
- Grub screw fixing on 8 mm high-grade alloy steel spindle
- Pair of concealed fixing bolt through roses
- **Sprung**, for use with **standard duty** followers
- Bolt through fixings included
- To suit doors up to **36-45 mm** thick
- 304 stainless steel
- Matching escutcheons available, see page 194
- Spindle type, see page 64 for details
- For recommended locks, see **Section 2** pages 15-17

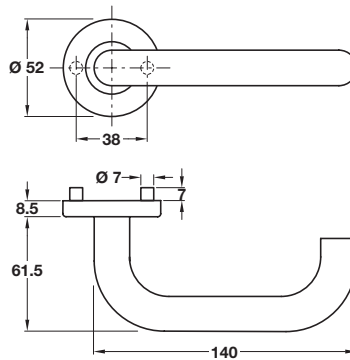

Finish	Cat. No.
Satin stainless steel	902.20.216

Order qty: 1 set

For all StarTec Commercial lever handles:

Drill two holes \varnothing 8 mm at 38 mm centres, to a minimum depth of 8 mm, and one \varnothing 22 mm hole to a depth of 2 mm

DIN EN 1906 - PfB

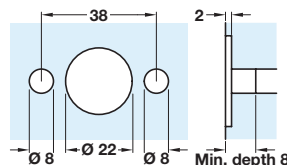
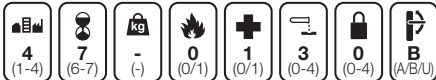

Satin stainless steel



StarTec
Commercial

B CHASE shaped lever handles, latch

- Pair of lever handles on latch backplates
- Grub screw fixing on 8 mm high-grade alloy steel spindle
- **Sprung**, for use with **standard duty** followers
- Bolt through fixings included
- To suit doors up to **38-47 mm** thick
- 304 stainless steel
- Spindle type, see page 64 for details
- For recommended locks, see **Section 2** pages 15-17

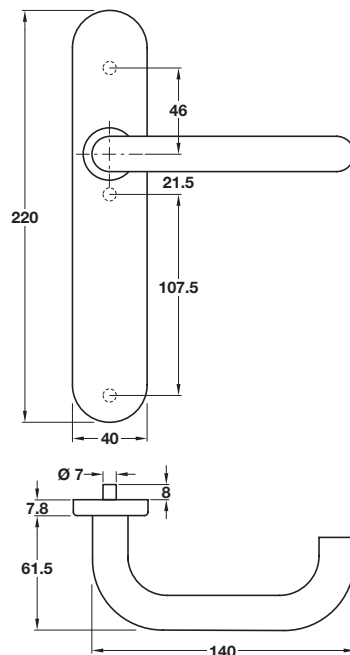

Finish	Cat. No.
Satin stainless steel	902.90.246

Order qty: 1 set

TCH-A1 2008, HUK. Dimensional data not binding. We reserve the right to alter specifications without notice.