

Extending Table Runners

Extending Table Runners for Tables with Frames



Important note: Unless otherwise indicated fixing screws are not included and must be ordered separately.

The symbol shown next to the drawing indicates the type and size of screw required.

Fixing materials can be found in **Section 11** from page 3.

Accessories for extending tables are shown on page 48

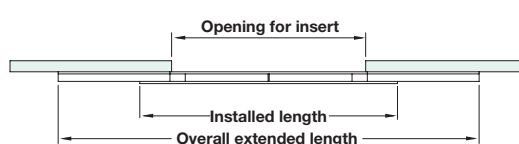
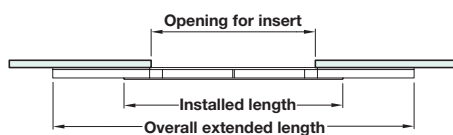
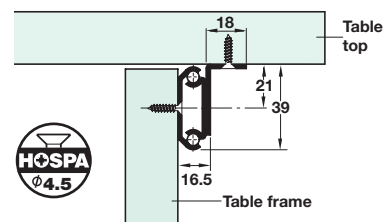
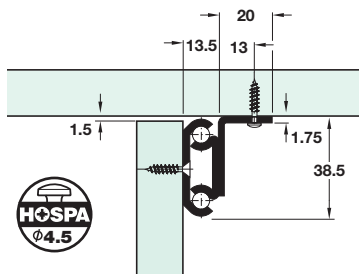
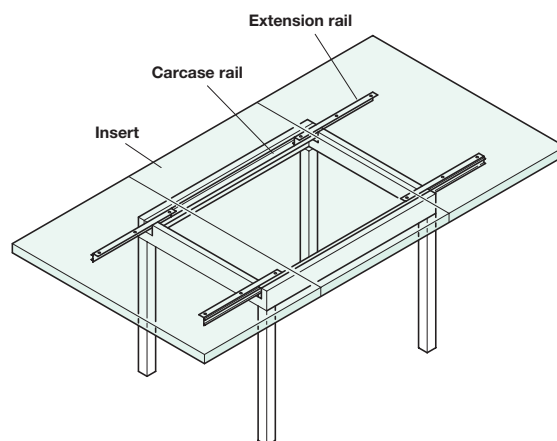
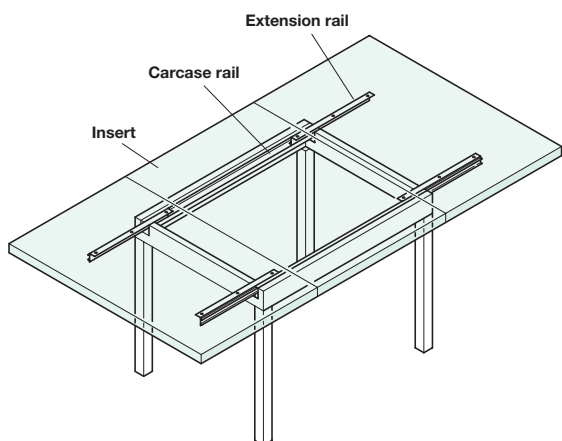

7

Castors, Feet, Legs and Table Fittings

A Extending table runners

- Simultaneous action; when one leaf is drawn back, the other withdraws automatically
- For square, rectangular, round or oval tables
- Maximum load carrying capacity **60 kg**
- Screw mounted to side of fixed table frame and underside of table
- Mounting bracket length 290 mm
- Galvanized steel

Installed length	750 mm
Overall extended length	1160 mm
Opening for insert	540 mm
Cat. No.	642.59.975

Order qty: 1 set

B Extending table runners

- Maximum load carrying capacity **60 kg**
- Screw mounting to side of fixed table frame and underside of table
- Galvanized steel

Installed length	650 mm	800 mm	1200 mm
Overall ext. length	1023 mm	1327 mm	2080 mm
Opening for insert	453 mm	610 mm	1010 mm
Cat. No.	642.56.659	642.56.800	642.56.926

Order qty: 1 set

TCH-FF 2010, HUK. Dimensional data not binding. We reserve the right to alter specifications without notice.