

A Fixed castor, plate fixing

- With screw on 60 x 60 mm mounting plate
- Without brake
- Galvanized steel housing with black polyamide wheel with grey solid rubber tyre

Wheel Ø	50 mm	75 mm
Wheel width	18 mm	25 mm
Overall height	71 mm	100 mm
Max load per wheel	approx 40 kg	approx 60 kg
Cat. No.	663.07.910	663.07.920

Order qty: 1 pc

B Swivel castor, plate fixing

- Without brake
- Two enclosed ball races are fitted in the ring mount
- There are maintenance free roller bearings in the hollow steel hubs secured with hub nuts
- Galvanized steel bracket and wheel, solid rubber profiled tyre

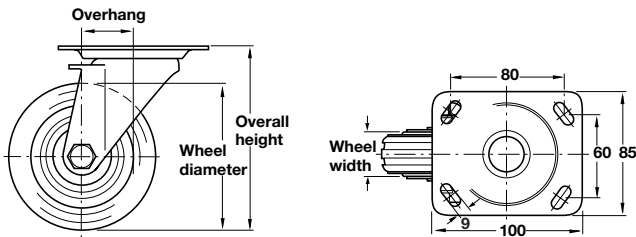

Wheel Ø	80 mm	100 mm	125 mm
Wheel width	25 mm	30 mm	37.5 mm
Overhang	35 mm	35 mm	40 mm
Overall height	100 mm	125 mm	150 mm
Max load per wheel	approx 50 kg	approx 70 kg	approx 100 kg
Cat. No.	670.01.209	670.01.218	670.01.227

Order qty: 1 pc

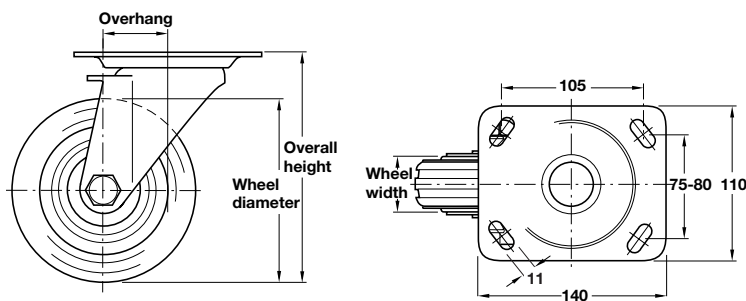

Wheel Ø	160 mm	200 mm
Wheel width	40 mm	50 mm
Overhang	60 mm	65 mm
Overall height	195 mm	235 mm
Max load per wheel	approx 135 kg	approx 205 kg
Cat. No.	670.01.245	670.01.263

Order qty: 1 pc

TCH-FF 2010, HUK. Dimensional data not binding. We reserve the right to alter specifications without notice.