

All suitable for use on soft floor coverings such as carpets

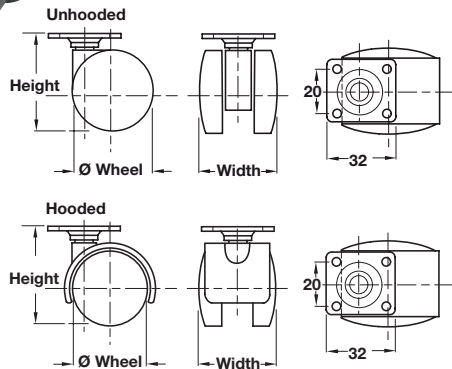

A Twin wheel castor, plate fixing

- With 32 x 32 mm mounting plate
- 20 x 20 mm screw hole distances
- Matt black plastic



Wheel Ø/ Static capacity	Height/Width	Without brake	With brake
Unhooded			
Ø 50 mm/ 45 kg	62/49 mm	660.62.351	-
Hooded			
Ø 40 mm/ 35 kg	54/38 mm	660.62.332	660.62.333
Ø 50 mm/ 45 kg	65/44 mm	660.62.352	660.62.353

Order qty: 1 pc



Important note: Unless otherwise indicated fixing screws are not included and must be ordered separately.

The symbol shown next to the drawing indicates the type and size of screw required.

Fixing materials can be found in **Section 11** from page 3.

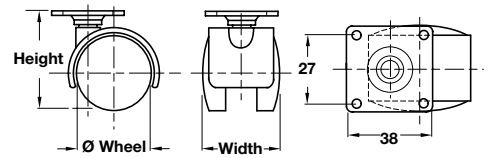

C Twin wheel castor, plate fixing, hooded

- With 38 x 38 mm mounting plate
- 27 x 27 mm screw hole distances
- Matt black plastic



Wheel Ø/ Static capacity	Height/Width	Without brake	With brake
Hooded			
Ø 40 mm/ 35 kg	53/38 mm	660.65.332	660.65.333
Ø 50 mm/ 45 kg	65/44 mm	660.65.352	660.65.353

Order qty: 1 pc

7

Castors, Feet, Legs and Table Fittings

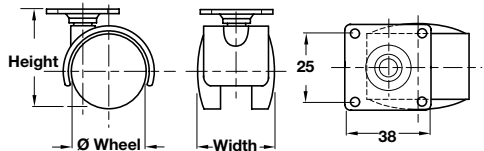

B Twin wheel castor, plate fixing, hooded

- With 38 x 38 mm mounting plate
- 25 x 25 mm screw hole distances
- Matt black plastic



Wheel Ø/ Static capacity	Height/Width	Without brake	With brake
Hooded			
Ø 40 mm/ 35 kg	54/38 mm	660.63.332	660.63.333
Ø 50 mm/ 45 kg	65/44 mm	660.63.352	660.63.353

Order qty: 1 pc

TCH-FF 2010, HUK. Dimensional data not binding. We reserve the right to alter specifications without notice.