

A Twin wheel castor, M8 thread fixing, hooded

- Suitable for use on soft floor coverings such as carpet
- With M8 x 16 mm **threaded bolt**
- For use with M8 T-nuts
- Matt black plastic

Wheel Ø/ Static capacity	Height/Width	Without brake	With brake
Ø 40 mm/ 35 kg	49/38 mm	660.66.332	660.66.333
Ø 50 mm/ 45 kg	62/44 mm	660.66.352	660.66.353

Order qty: 1 pc



Dull finish



Galvanized finish

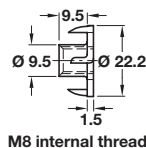

M8 internal thread

B M8 T-nuts, knock-in

- With four prongs
- For use in mounting M8 thread fixing castors under wooden bases
- Steel

Finish	Ø	Cat. No.
Dull	Ø 9.5 mm	031.00.285
Galvanized	Ø 9.5 mm	031.00.481

Order qty: Multiples of 100 pcs

Photo shows castor with brake,
illustration shows castor without brake

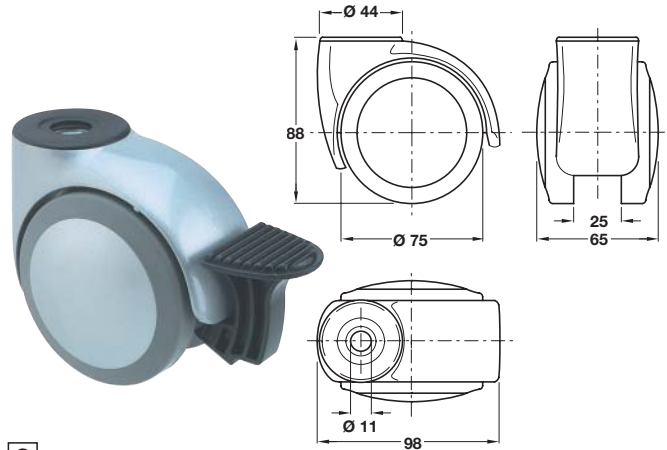

C Twin wheel castor

- Maximum load carrying capacity **100 kg** per castor
- Housing: Silver coloured RAL 9006 plastic
- Wheel: Mid grey rubber
- Brake: Black plastic
- **Order Ø 11 mm pin separately**

	Without brake	With brake
Cat. No.	660.91.245	660.90.245

Order qty: 1 pc

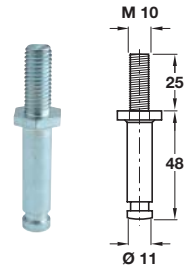

D Pin, Ø 11 mm, with M10 thread

- M10 x 25 mm
- Steel

Finish	Cat. No.
Galvanized	660.92.900

Order qty: 1 pc

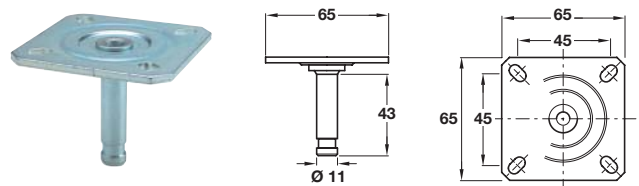

E Pin, Ø 11mm, with mounting plate

- Steel

Finish	Cat. No.
Galvanized	660.92.910

Order qty: 1 pc

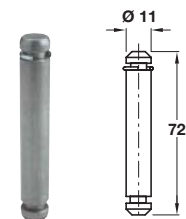

F Pin, Ø 11mm, with circlip

- Steel

Finish	Cat. No.
Bright steel	660.92.940

Order qty: 1 pc

TCH-FF 2010, HUK. Dimensional data not binding. We reserve the right to alter specifications without notice.