

Photograph shows castor with brake,  
illustration shows castor without brake

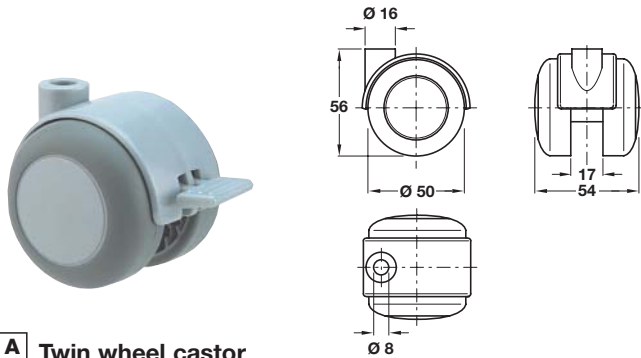

**A Twin wheel castor**

- Maximum load carrying capacity **40 kg** per castor
- Housing: Aluminium coloured plastic  
Wheel: Mid grey rubber  
Brake: Mid grey plastic
- **Order Ø 8 mm pin separately**

	Without brake	With brake
Cat. No.	660.91.903	660.90.903

Order qty: 1 pc



**C Pin, Ø 8 mm, with L mounting plate**

- For use with Item **A**
- Blackened steel

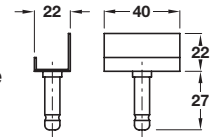

Finish	Cat. No.
Galvanized	660.92.970

Order qty: 1 pc

7

Castors, Feet, Legs and Table Fittings

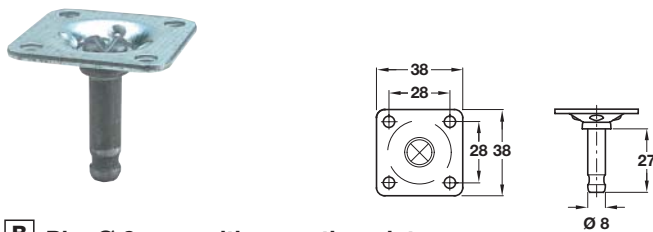

**B Pin, Ø 8 mm, with mounting plate**

- For use with Item **A**
- Steel

Finish	Cat. No.
Galvanized	660.92.960

Order qty: 1 pc



**D Pin, Ø 8 mm, with M8 thread**

- M8 x 15 mm
- For use with Item **A**
- Steel

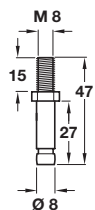

Finish	Cat. No.
Galvanized	660.92.980

Order qty: 1 pc

TCH-FF 2010, HUK. Dimensional data not binding. We reserve the right to alter specifications without notice.