

A Roller glide

- Particularly suited where height restriction applies, 11 mm maximum distance between floor and base of furniture
- By changing position of the roller the distance from the floor to the base of the furniture can vary from 11 to 9.5 mm
- Inner wheel housing swivels 360° within outer housing
- Can be used for mobile pedestals that are stored under desktops
- Black plastic

	Cat. No.
Roller glide	661.05.306

Order qty: 1 pc

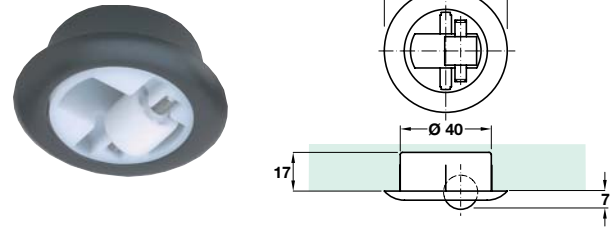

C Roller glide

- For embedding into base of furniture
- Wheel Ø 15 mm
- Inner housing (white section) swivels 360° within outer housing
- Maximum load carrying capacity **50 kg** per castor
- Black/white plastic

	Cat. No.
Roller glide	661.04.309

Order qty: 1 pc

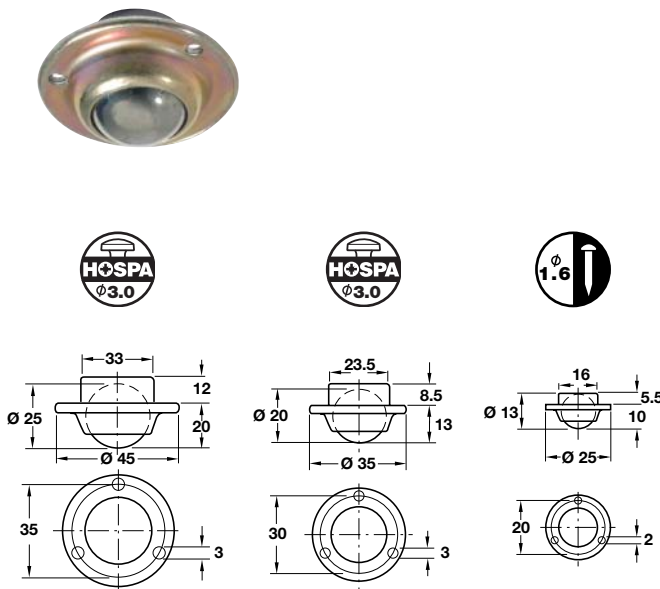

B Ball castor

- Without brake or swivel
- Maximum load carrying capacity between **6 kg** and **17 kg**
- Screw fixed mounting plate and low installation height
- If mounted with ball uppermost, can be used as a conveyor system roller
- Yellow chromated steel housing with reinforced base
- Chrome-plated steel ball

Load capacity	Diameter	Cat. No.
6 kg	13 mm	661.02.210
12 kg	20 mm	661.02.230
17 kg	25 mm	661.02.250

Order qty: 1 pc

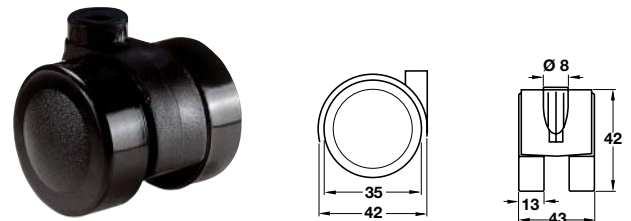

D Twin wheel castor

- Ø 35 mm
- With or without brake
- Maximum load carrying capacity **75 kg** per castor
- For use with pin and mounting plate **E**
- Black plastic

	Without brake	With brake
Cat. No.	660.46.300	660.47.300

Order qty: 1 pc

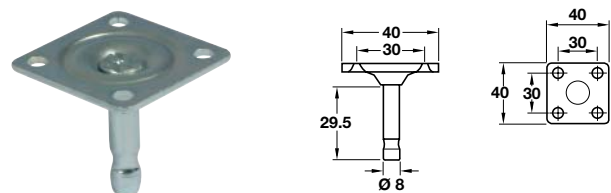

E Pin and mounting plate

- For mounting castors **D**
- Galvanized steel

	Cat. No.
Pin and mounting plate	660.46.990

Order qty: 1 pc