

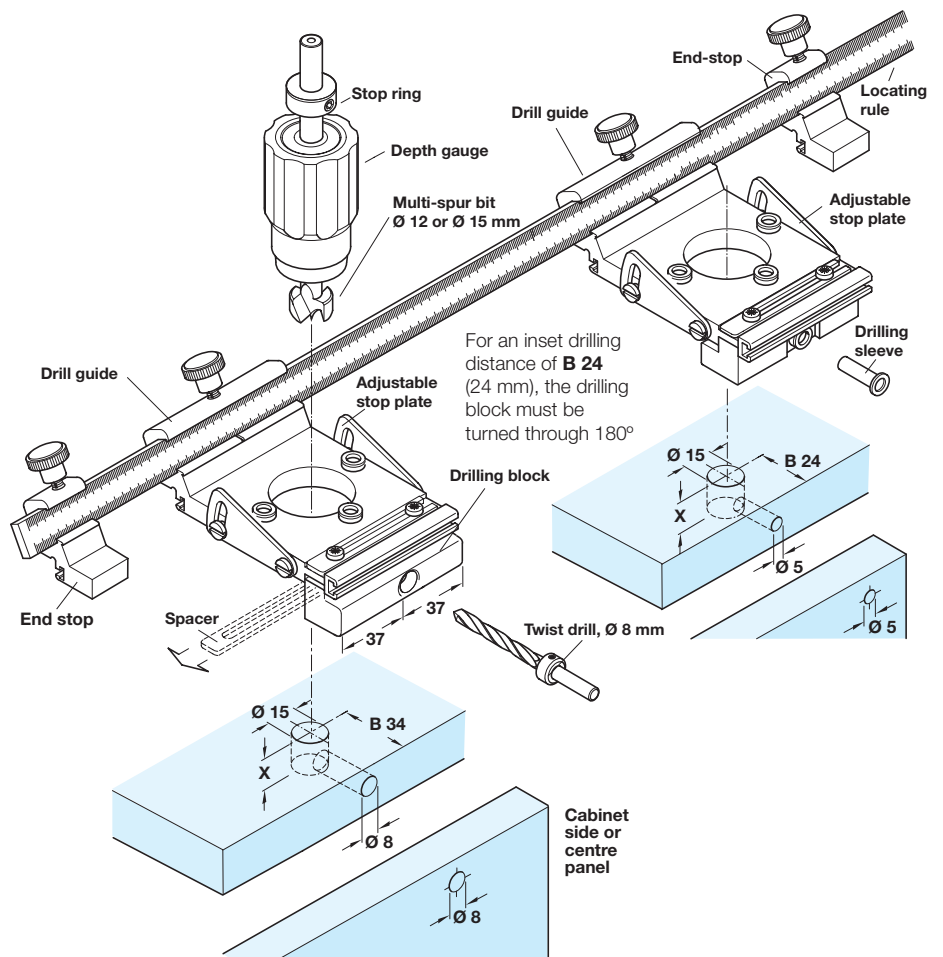

Unitool Minifix drilling jig

- For precise drilling of Minifix 12 and 15 connectors
- By using the spacers provided, the drill guide allows for board thicknesses 16, 19 and 23 mm
- One drill guide is used for simple unit installation
- Using 2 drill guides with the locating rule, gives a complete production jig
- The stop plates allow an inset drilling distance of 37 mm



A Unitool Minifix 12 and 15 drilling jig

- Comprising:
 - 1x Locating rule with double-ended scale, 800 x 15 x 6 mm
 - 2x Drill guides with adjustable stop plates and drilling block
 - 1x Drilling sleeve for bolt holes Ø 5 mm
 - 2x End stops
- As supplied, the jig is set up for 19 mm thick board with an inset drilling depth of 34 mm

Set	Cat. No.	Order qty
Unitool Minifix 12 and 15 drilling jig	001.25.404	1 set
Accessories		
Additional Minifix drill guide, with adjustable stop plates	001.25.413	1 pc
Drilling bush for for Ø 5 mm bolt hole	001.25.806	1 pc
Depth gauge for drill bits with Ø 10 mm shank	001.28.750	1 pc
Carbide multi-spur bit, Ø 12 mm, Ø 10 mm shank	001.24.489	1 pc
Carbide multi-spur bit, Ø 15 mm, Ø 10 mm shank	001.24.443	1 pc
HSS twist drill for Ø 5 mm holes	001.41.168	10 pcs
HSS twist drill for Ø 8 mm holes	001.41.248	10 pcs
Stop ring for drill bit, Ø 5 mm	001.42.665	1 pc
Stop ring for drill bit, Ø 8 mm	001.42.683	1 pc
Locating rule with 800 mm double-ended scale	001.27.793	1 pc
End stop, with clamping screw	001.27.757	1 pc
Scribing pin, screws into end stop	001.27.775	1 pc

Marking device:

Simply remove the clamping screw from the end stop and screw in the scribing pen

Locating rule with 2 end stops for checking wood components up to 800 mm wide

Transfer measurements for similar types of wooden components using rule, scribing pen and end stop

Circles up to 1600 mm in diameter can be drawn using the rule and two scribing pins

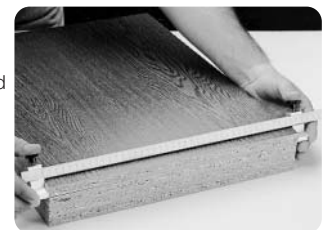
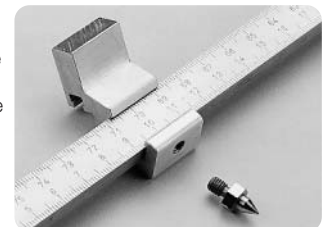

TCH-FF 2010, HUK. Dimensional data not binding. We reserve the right to alter specifications without notice.