

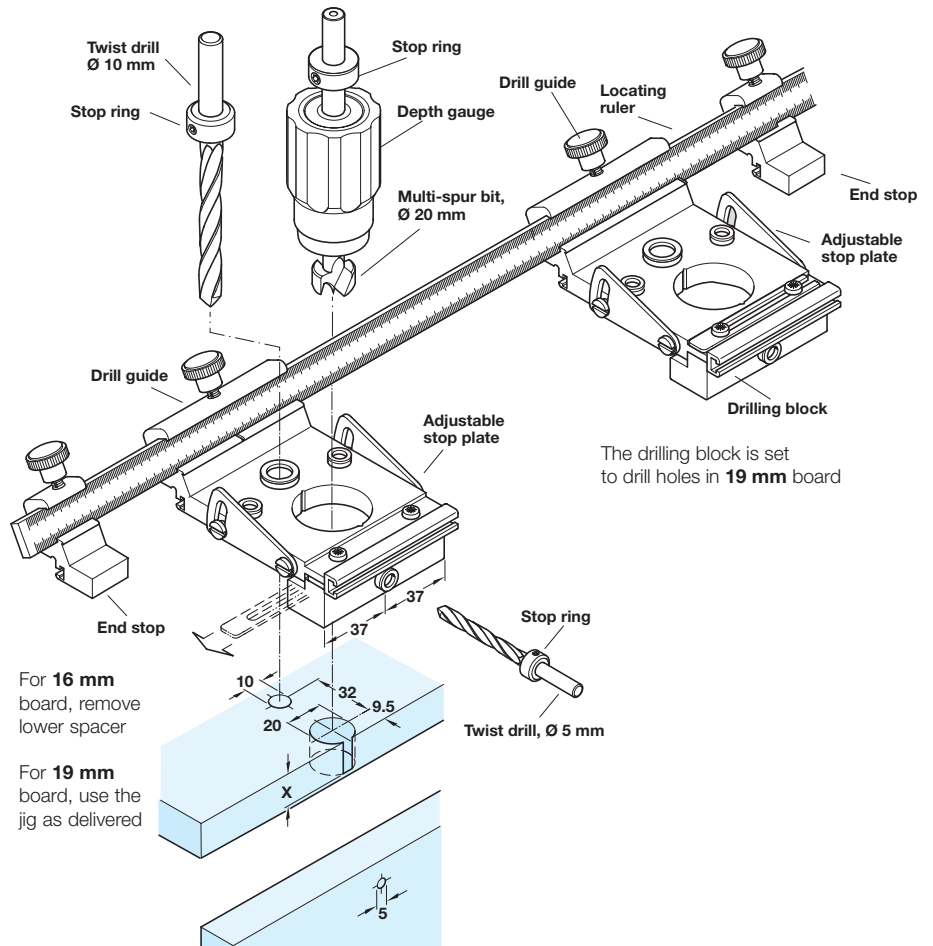

- **Unitool Rafix drilling jig**
- For use with Rafix fittings
- By using the spacers provided the drill guide allows for board thicknesses 16 and 19 mm
- One drill guide is used for simple unit installation
- Using 2 drill guides with the locating rule, gives a complete production jig
- The stop plate allows an inset drilling distance of 37 mm



TCH-FF 2010, HUK. Dimensional data not binding. We reserve the right to alter specifications without notice.

A Unitool Rafix drilling jig

- Comprising:
 - 1 x Locating ruler with double-ended scale 800 x 15 x 6 mm
 - 2 x Drill guides with adjustable stop plates and drilling block
 - 2 x End stops

Set	Cat. No.	Order qty
Unitool Rafix drilling jig	001.25.208	1 set
Accessories		
Additional drill guide with adjustable stop plates	001.25.217	1 pc
Depth gauge for drill bits with Ø 10 mm shank	001.28.750	1 pc
Carbide multi-spur bit, Ø 20 mm, for Ø 16 mm	001.24.407	1 pc
Carbide multi-spur bit, Ø 20 mm, for Ø 19 mm	001.24.416	1 pc
HSS twist drill for Ø 5 mm holes	001.41.168	10 pcs
HSS twist drill for Ø 10 mm holes	001.41.293	10 pcs
Stop-ring for Ø 5 mm drill bit	001.42.665	1 pc
Stop-ring for Ø 10 mm drill bit	001.42.693	1 pc
Locating rule with 800 mm double-ended scale	001.27.793	1 pc
End stop with clamping screw	001.27.757	1 pc
Scribing pin, screws into end-stop	001.27.775	1 pc

Marking device:

Simply remove the clamping screw from the end stop and screw in the scribing pin

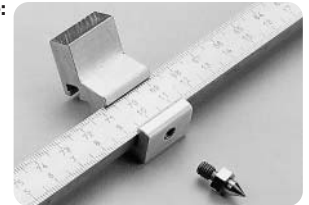

Locating ruler with 2 end-stops for checking out wooden components up to 800 mm wide



Transfer measurements for similar types of wooden components using the rule, scribing pin and end-stop



Circles up to 1600 mm in diameter can be drawn using the rule and two scribing pins

