

Shower-lite extractor fan set,
standard and timer version, shown on page 94

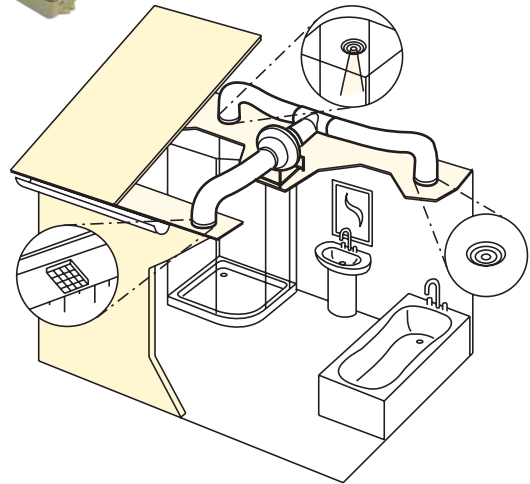

Professional Showerlite

- 12V extractor fan incorporating an integral 12V 35W halogen lamp
- Extracts up to 180m³/hr, 50 litres per second
- Complies with EN 60335-2-80
- Meets 2006 building regulations Doc F1
- Consists of:
 - 1x 12V/35W Halogen lamp, polished chrome fascia
 - 1x white internal vent
 - 1x Transformer input 230V AC Output 12V AC Max.
 - 1x Extractor fan
 - 1x Fixing set
 - 1x External vent
 - 1x Fitting instructions



Finish	Cat. No.
Polished chrome/white	828.01.730

Order qty: 1 set

4 Ventilation



Centrifugal in-line fan set

- Available in standard or timer version
- **Standard version:** switches on and off when light switch is switched on and off
- **Timer version:** switches on when light switch is switched on. Once switched off will automatically run between 20 secs - max. 15 mins
- Extracts up to 110m³/hr, 31 litres per second
- Complies with EN 60335-2-80
- Meets 2006 building regulations Doc F1
- Consists of:
 - 1x Internal vent, white fascia
 - 1x Internal vent, polished chrome fascia
 - 1x Transformer input 230V AC Output 12V AC Max.
 - 1x Extractor fan
 - 1x Fixing set
 - 1x External vent
 - 1x Fitting instructions

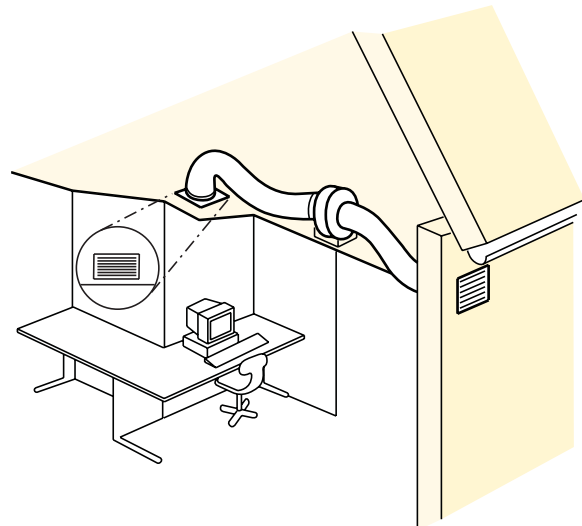

Finish	Standard version	Timer version
Polished chrome/white	828.01.740	828.01.741

Order qty: 1 set

TCH-FF 2010, HUK. Dimensional data not binding. We reserve the right to alter specifications without notice.