

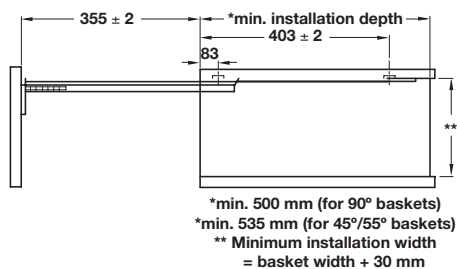

Pull out storage units for 300 and 400 mm wide cabinets

Order frames, baskets and brackets separately

Please note: Baskets should be hung from the second bar down and not the top bar



Pull out storage unit frame

- For use with baskets and brackets shown right
- Unhanded, universal two-way runners
- Minimum installation depth 480 mm
- Minimum installation height 660 mm
- Silver epoxy coated tubular steel

Handed	Left	Right
Cat. No.	545.65.942	545.65.932

Order qty: 1 pc

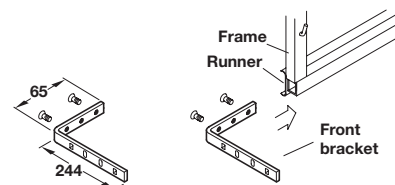

Door front bracket, 90°

- Adjustable for left or right hand mounting
- Elongated holes for vertical adjustment
- Silver epoxy coated steel

Door front bracket, 90°	
Cat. No.	545.65.999

Order qty: 1 pair

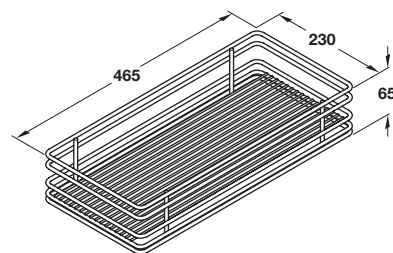

Storage basket set

- 3 baskets per set
- Suitable for 300 mm or wider cabinets
- Heavier gauge chrome-plated steel

Cabinet width	Cat. No.
300 mm	545.65.252

Order qty: 1 set

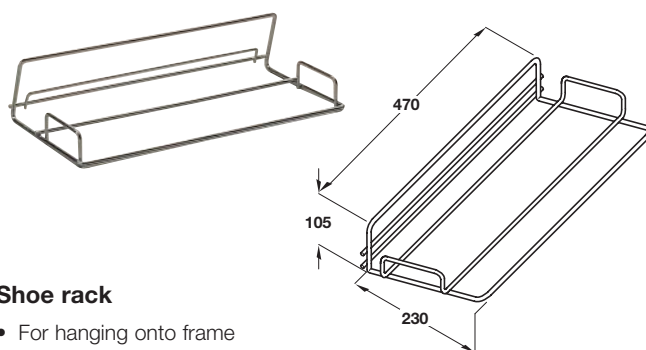

Shoe rack

- For hanging onto frame
- Heavier gauge chrome plated steel

Shoe rack	
Cat.No.	805.76.200

Order qty: 1 pc



Pull out storage basket

- Full extension ball bearing runners
- 450 mm installation depth
- 140 mm height
- Side fixing, fixings included
- Polished chrome-plated steel



For cabinet width	Width	Cat. No.
400 mm	364 mm	805.92.208
450 mm	414 mm	805.92.209
500 mm	464 mm	805.92.200
600 mm	564 mm	805.92.201
800 mm	764 mm	805.92.203
900 mm	864 mm	805.92.204
1000 mm	964 mm	805.92.205

Order qty: 1 pc

TCH-FF 2010, HUK. Dimensional data not binding. We reserve the right to alter specifications without notice.