

- Variantool-N drilling jig for drilling \varnothing 3 mm or \varnothing 5 mm holes consistently at 32 mm intervals
- The jig allows for an inset distance from the front carcass edge of 37 mm and from the back edge of 60 mm
- Integral sliding positioning tabs ensure consistent drilling locations
- An ideal addition to the other Unitool drilling jigs, for drilling series of holes in a line or groups of holes according to

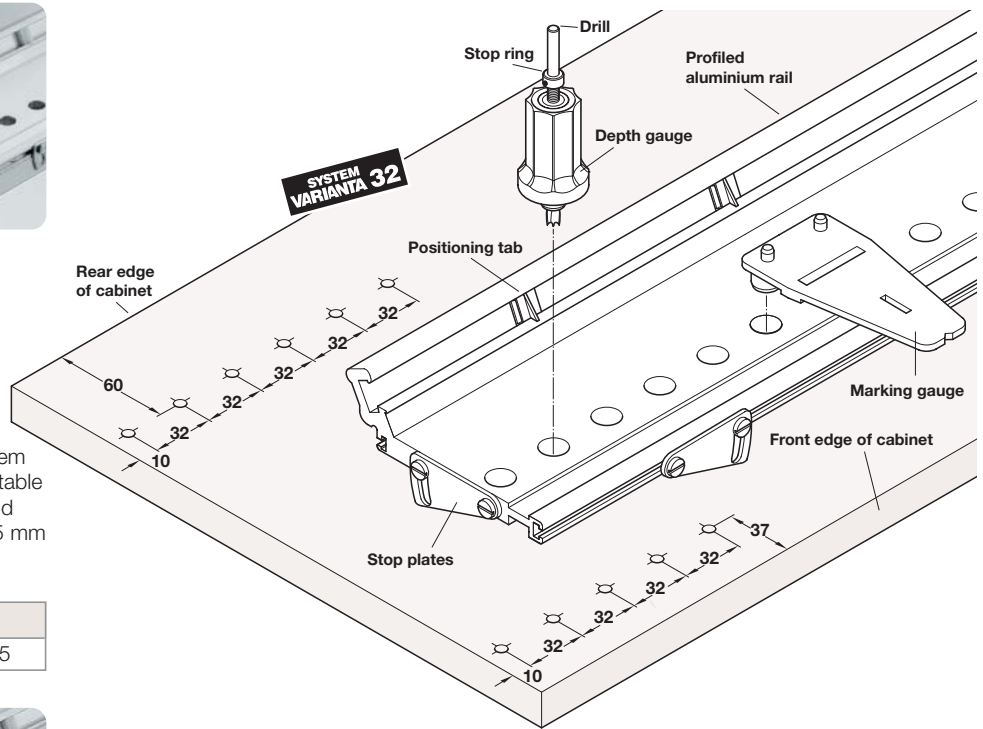
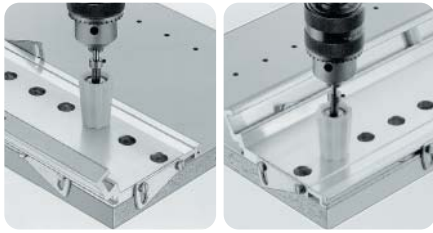

A Variantool-N drilling jig

- Comprises: 1x profiled aluminium rail E6-treated, 1172 x 120 x 10 mm for 37 holes at 32 mm intervals (other system intervals available on request), 8x adjustable stop plates for edge distances of 37 and 60 mm, 1x locating pin for \varnothing 3 and \varnothing 5 mm holes, 5x positioning tabs, 1x plastic marking gauge

	Cat. No.
Drilling jig	001.27.015

Order qty: 1 set

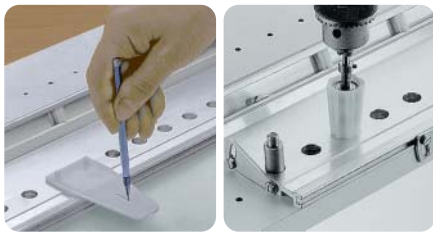

If drilling positions between the 32 mm series drilled holes are required, e.g. for concealed hinges, the position can be transferred to the corresponding workpiece from the drilling jig or the appropriate \varnothing 5 mm series drilled hole

If more holes are required than the jig provides, it can be repositioned lengthwise and located by inserting the locating pin in a previously drilled hole

Inserting drills in the depth gauge

1. Insert \varnothing 3 or \varnothing 5 mm drill into depth gauge from below
2. Push spiral spring and stop ring onto drill bit
3. Set drilling depth by adjusting stop ring after trial operation

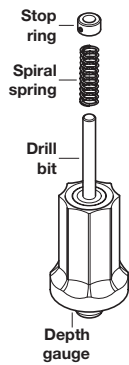

B Drill bit

- With centering tip
- Shank \varnothing 5 mm, length 107.5 mm

For bolt hole	Cat. No.
\varnothing 3 mm	001.24.472
\varnothing 5 mm	001.24.434

Order qty: 1 pc

C Depth gauge

- With 2 ball bearings, stop ring, spiral spring and allen key for \varnothing 5 mm shank drill-bits
- Plastic

	Cat. No.
Depth gauge	001.28.710

Order qty: 1 pc



D Adjustable line boring jig, 32 mm system

- Drilling tool fits exactly in insert without allowing drill bit to touch jig
- Provides a self centering bore
- Design prevents clogging by wood chips
- Bits are interchangeable, only one guide necessary
- **Order self centering drilling tool and boring bit separately**
- High impact plastic with aluminium inserts

Item	Cat. No.
Drill boring template	001.27.007
Self centering drilling tool	001.28.600
Boring bit, 5 mm Carbide.RH	001.24.700
Boring bit, 1/4" Carbide.RH	001.24.710

Order qty: 1 pc



E Drilling depth stop

- For drill bits with \varnothing 10 mm shank and maximum drilling \varnothing 35 mm
- The stop will not continue to turn when it comes into contact with the material, thus no damage is done to the surface
- Aluminium with steel ring

	Cat. No.
Drilling depth stop	001.28.129

Order qty: 1 pc



F Countersunk machine bit

- For use with wood
- Special alloy tool steel

\varnothing hole	Cat. No.
16 mm	001.26.116

Order qty: 1 pc