

Pull out storage unit

- For 150 mm minimum cabinet width
- Right handed
- Set includes:
 - 1x Hanging frame, right handed, chrome-plated steel
 - 2x Ball bearing runners, galvanized steel
 - 2x Door brackets, silver chrome-plated steel
 - 2x Storage baskets, chrome-plated steel
- Fixings included

For cabinet width 150 mm	Cat. No.
Right hand	545.25.220
Acrylic inserts - 1 pair	
White	545.25.790
Black	545.25.390

Order qty: 1 pc

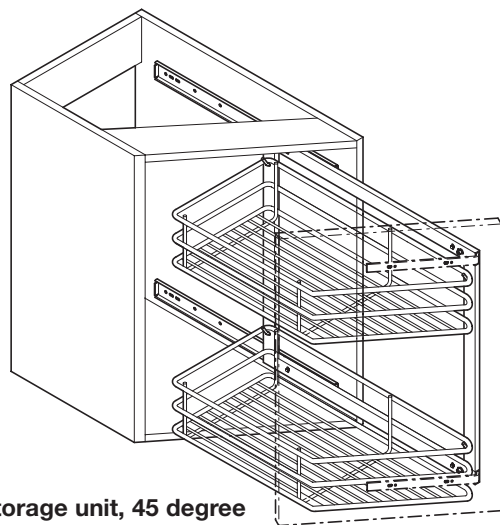

Pull out storage unit, 45 degree

- Suitable for 300 mm cabinet
- For cabinets with angled door fronts (silver painted stainless steel bracket included)
- Chrome linear baskets
- Handed - left hand shown
- Set includes:
 - 2x Chrome linear baskets
 - 2 pairs x Full extension ball bearing runners, galvanized steel

For 300 mm cabinet width	Cat. No.
Left hand	545.25.263
Right hand	545.25.273
Acrylic inserts - 1 pair	
White	545.25.793
Black	545.25.393

Order qty: 1 pc



Photo shows left hand version

TCH-FF 2010, HUK. Dimensional data not binding. We reserve the right to alter specifications without notice.