

1, Create Rough Opening In Stud Wall

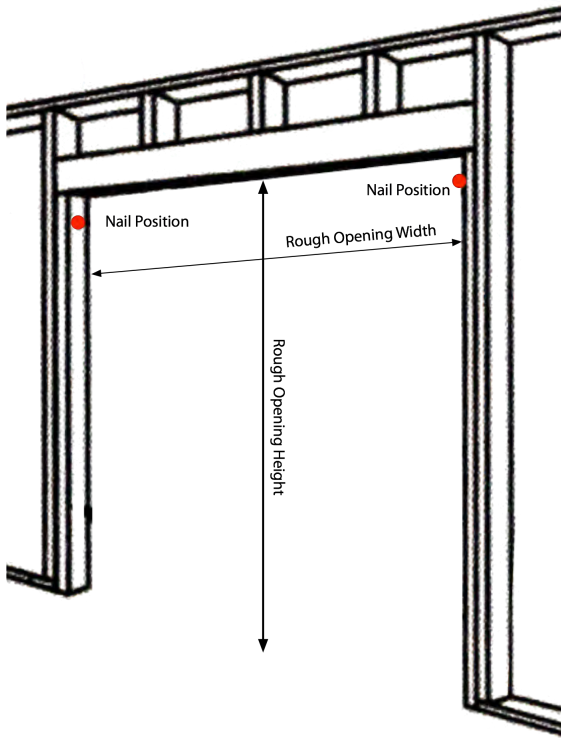

Construct rough opening ensuring all sides are square and level.

Rough opening should be;

Height = Door height + 114mm (4½")

Width = 2x Door Width + 25mm (1")

Drive a nail into each side of the structural opening at door height + 38mm (1½") and leave enough exposed to hook head unit onto them via the slots on the metal plates at either end.

Please note all height dimensions are based on a Structural Floor. This will give you a 30mm gap under the door. This will reduce when applying a floor finish. If no further finish is being applied then reduce height of rough opening and Support Nail locations to suit.

On a Glass door the gap from bottom of glass to floor level will always be 11mm. No changes to calculations above are needed. The Glass floor guide must always sit on top of any finish applied.

2, Timber Head Unit Preparation

On the head unit there are marks denoting door sizes both on the side nailers and on the top surface. These are marked out for;

PD1 - 608mm (2'0), 712mm (2'4"), 762mm (2'6") 813mm (2'8"). Full uncut header is 915mm (3')

PD2 - 915mm (3'0), 1016mm (3'4"), 1067mm (3'6"), 1118mm (3'8"). Full Uncut Header is 1219mm (4')

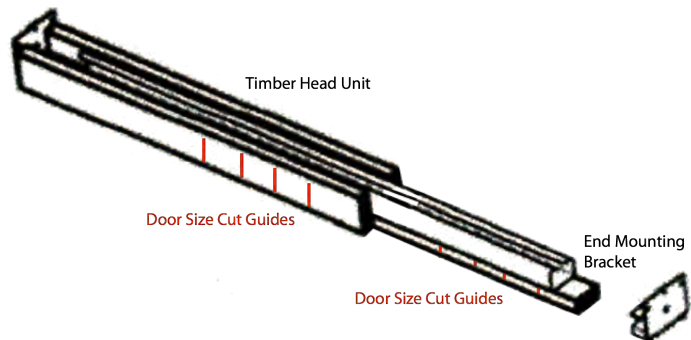

If you are cutting the header to a bespoke size you will need to bear in mind that the markings on the top of the header are double spaced - for example the 2'4" mark is 8" away from the 2' mark, not 4". This is due to the calculations being based on overall track length. Side Nailers are correctly spaced as these only set the door opening. Calculate your sizes based on the above information.

To adjust head unit;

1, Remove end mounting bracket from narrow end of Timber Head Unit

2, Find the correct position on the top surface (above track) and cut through both timber and track. Once you have done this then cut a further 38mm (1½") off of the track only. This then gives room to re-attach mounting bracket at the end.

3, Find the correct position on the side nailers but cut through the Side Nailers only. Carefully remove unwanted piece and if required carefully remove staple holding it in place.

Please see Size Calculator which gives examples of critical data dependant on door or opening sizes. A Interactive version is available to download from our website.

Pocket Door Kit Calculator

Glass Size Calculator.

Only input data into red boxes as the rest are calculated automatically

Opening Height - From Structural Floor To Bottom Of Side Nailer (mm)	1986
Rough Opening - From Structural Floor (mm)	2100
Support Nail Height - From Structural Floor (mm)	2024
Gap Bottom Of Door To Both Structural Or Finished Floor (mm)	11
Finished Floor Level Thickness (mm)	0
Glass Panel Height (mm)	1939
Opening Width - Closing Jamb To Steel Wrapped Studs (mm)	726
Rebate Depth on Jamb (mm)	10
Overlap Into pocket (mm)	10
Total Glass Width (mm)	746

Structural opening = Surface the Stud Foot Bracket is fitted to. Should no additional coverings be applied then place 0 in "Finished Floor Level Thickness" box above.

Finished Floor Level = Includes any floor covering over and above the surface that the Stud Foot Bracket is fitted to. Enter Thickness in "Finished Floor Level Thickness" box above.

On Glass Pocket Door Kit the Floor Guide must be fitted to the Finished Floor Level if applicable.

Timber Door Calculator

Only input data into red boxes as the rest are calculated automatically

Timber Door Height (mm)	180
Rough Opening - From Structural Floor (mm)	294
Support Nail Height - From Structural Floor (mm)	218
Gap Bottom Of Door To Structural Floor (mm)	30
Finished Floor Level Thickness - If Any (mm)	0
Gap Bottom Of Door To Finished Floor Level (mm)	20
Adjustment To Support Nail Height For Finished Floor Level (mm)	-10
Timber Pocket Door Kits can be specified with softclose & EZ Closer.	
Glass Pocket Door Kits can only be specified with EX Closer.	
Brush Strip trims will control the door to a degree and would work against Softclose.	

3, Install head unit

- 1, Ensure Header is positioned so that the Side Nailers are above the proposed door opening.
- 2, Position Header into place by hooking End Plates over the Support Nails previously inserted each side of the rough opening.
- 3, Once you have levelled the Header and are happy with it's position finish driving Support Nails into the side timbers. Then drive remaining nails into the plates on either side to secure checking head unit is still level after each nail is driven home.

4, Install Support Studs

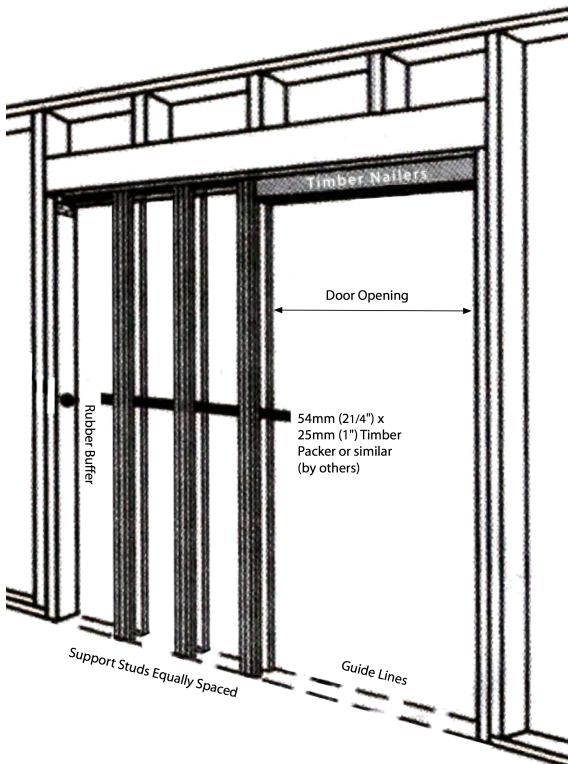

Steel Wrapped Studs are supplied already suitable for door heights of either 2032mm (6'8") doors in a PD1 kit or 2400mm (8') in a PD2 kit. If required cut to suit Header height and ensure studs are cut so they finish flush with top of Header for optimum support and strength.

Mark or use chalk lines to project positions of rough side studs across the rough opening.

Fit the first pair of Steel Wrapped Studs tight up against Side Nailers - timber surface facing outwards - by first fitting the Stud Foot Bracket on the floor as required - between the marks placed across opening (step 2) so that the 1st pair of Studs are plumb.

Position remaining Steel Wrapped Studs - timber surface facing outwards - equally between 1st pair and rough stud at rear of pocket area by first fitting the Stud Foot Brackets on the floor as required - between the marks placed across opening (step 2) so that the 2nd and 3rd pairs of Studs are plumb and evenly spaced.

5, Install Rubber Buffer

Fix Rubber Buffer at rear of pocket on rough stud at half door height. You will need to pack the Buffer to suit your required door position when open - 2 examples are either fully retracted or sitting 100mm within opening.

An optional touch latch is available which allows the doors to sit flush within the architrave. When pressed and released the door then pops out of the cavity and then closes as normal. When sliding open you again press the doors and they are then held flush. This would replace the buffer and is installed into the door. Instructions are provided with the latch.

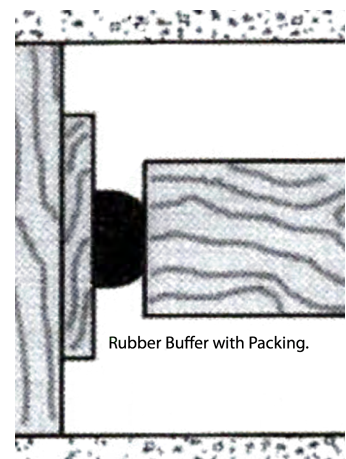

Optional Touch Latch

6, Install Wall Facing

IMPORTANT - PLACE TIMBER PACKER BETWEEN ALL 3 ROWS OF STUDS BEFORE WALL FACING INSTALLATION.

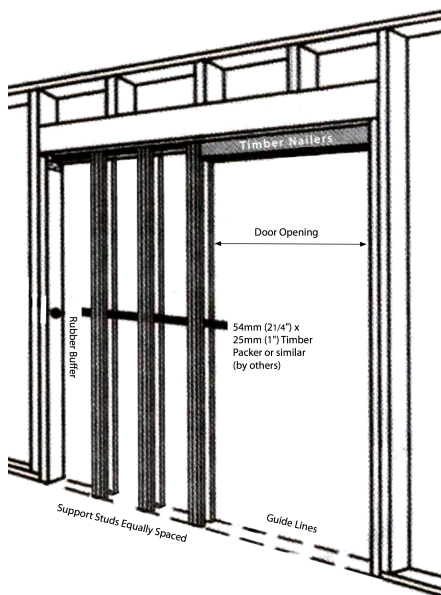

Insert timber packer between all 3 pairs of Steel Wrapped Studs so they are not bent or distorted during wall facing installation. Ideal size would be around 54mm (2¼") wide x 25mm (1") high.

Apply wall facings (Plasterboard, Plywood, MDF etc...) at a thickness to suit your application. Secure with screws but bear in mind when selecting screws to fix wall facings that the timber infills on the support studs are 15mm (5/8") thick. **Do not over-tighten.**

Please note there will be a slight flex on the cavity walls if thin Plasterboard is used. If being used where probability of side loading is likely then consider using Ply or MDF as a stronger alternative. Alternatively double up on Plasterboard.

Bear in mind that there is an approx. 4mm difference between the Timber nailers and the support studs so plan for this when adding the wall facing.

Once work on the pocket is complete remove the packer.

7a, Timber Door Installation

1, Position Hanger Mounting Plates around 90mm (3½") from either edge of the door. Ensure both plates are the same way round with the clips on the same side. As the screws are quite large we recommend drilling pilot holes first.

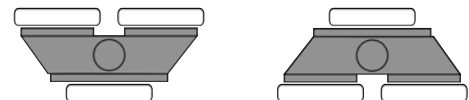

Hanger Configuration

2, With the hangers equally adjusted so the bolt tip sits flush with the tops of the brass threaded bodies position them into the track so that one hanger has 1 wheel and the other has 2 wheels on one side.

3, Offer the door into the opening with the rear edge sitting between 1st pair of Steel Wrapped Studs. Use packers at bottom of door to help you locate hanger plates onto the hanger bolts. Once in position swing the white locking clip around bolt head and press firmly to lock in position.

As the bottom guides are not installed at this point be careful when testing door and sliding into the cavity.

4, To remove the door for replacement or redecoration carefully unclip hangers and remove door when happy with how it works. Secure hangers together and position above door opening so they do not inadvertently enter cavity whilst installing wall facing.

5, Fix any required skirting board, architrave and trim around opening. Please note that we recommend the trim either side of the track above the door opening should be removable so that in the event the door needs to be removed, no damage is done.

6, Finally place the guides at the bottom of the opening so that they make contact with the bottom edges of the door only. If they contact the sides of the door marking can occur. On 44mm doors you may need to recess guides into trim in order for them to fit.

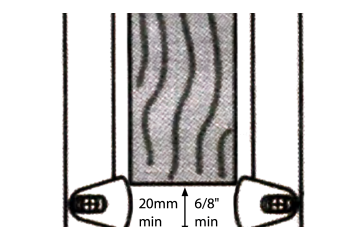

Section Showing Timber Door Installation

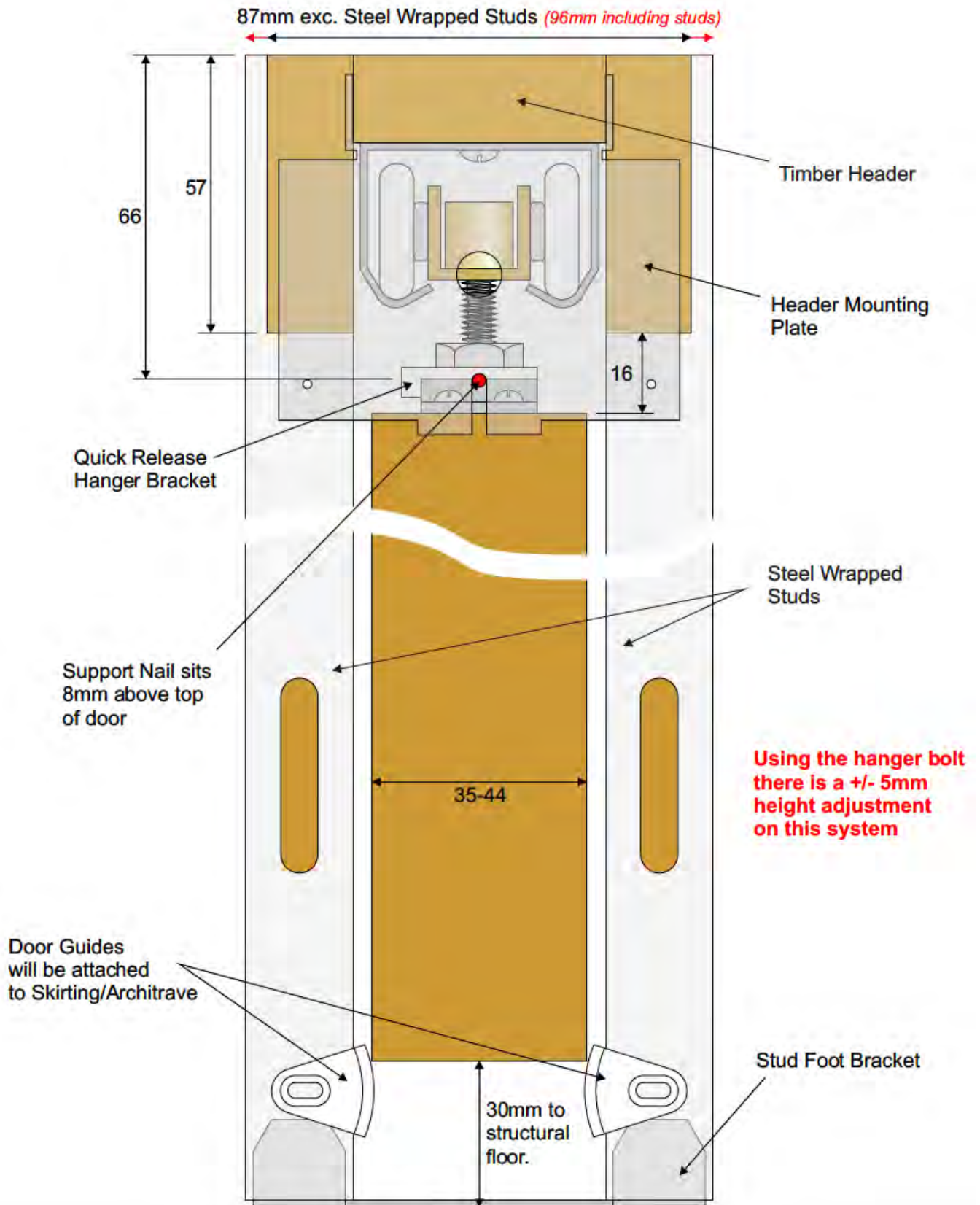

7b, Glass Door Installation

Glass Size Calculator.	
Only input data into red boxes as the rest are calculated automatically	
Opening Height - From Structural Floor To Bottom Of Side Nailer (mm)	1986
Rough Opening - From Structural Floor (mm)	2100
Support Nail Height - From Structural Floor (mm)	2024
Gap Bottom Of Door To Both Structural Or Finished Floor (mm)	11
Finished Floor Level Thickness (mm)	0
Glass Panel Height (mm)	1939
Opening Width - Closing Jamb to Steel Wrapped Studs (mm)	726
Rebate Depth on Jamb (mm)	10
Overlap into pocket (mm)	10
Total Glass Width (mm)	746

The example shown here is from our Glass Size Calculator.

Based on a example Opening Size of 1986mm high x 762mm wide and the addition of no further flooring the glass height would be 1939mm If extra flooring had been applied then the thickness of it would be subtracted from glass size.

Width of glass is essentially opening size plus 20mm which allows for slight overlap of the glass into the cavity and 10mm rebate on closing jamb.

This Glass Calculator is available for download on our website.

In the box containing the glass clamps you have the choice of either 10 or 12mm glass. To set the thickness place the required oval packers into the top of the clamps before fitting to the glass.

Place the clamps at each end of the glass door and set them in 15mm from the edges. On the clamps are 2 sets of 3 allen keys. Tighten these starting with the middle on each side first and then the outer ones to finish.

Remove the timber fixing plates and the bolts from the 3 wheel hangers from the original pocket door kit and insert the glass clamp bolts (with nuts) onto the hanger bodies.

With the hangers equally adjusted so the bolt tip sits flush with the tops of the brass threaded bodies position them into the track so that one hanger has 1 wheel and the other has 2 wheels on one side. Place the door guide on the floor between the front studs in a central position. Adjust it to suit the glass thickness you are using.

Offer the door up to the hanging bolts and locate the bolt heads into the slots on the fixing clamps.

Once engaged use a 6mm spanner and engage to the flats on the pendant bolts. Now turn to adjust either up or down until door is level and you have the correct tolerance at the bottom of the door.

Once happy, lock into place by tightening the nut on the pendant bolt down onto the clamp body.

Now attach the full length clamp cover rail by engaging the top and then firmly pressing down until it clicks onto the clamp at either side. 2 End Caps are provided - however on a Pocket Door theres no need to fix one at the back of the door as it will never be seen. They simply press in to the ends with the cut out sitting over the glass.

At this point you need to also apply the brush strip - both either side across the top and either side of the door where it disappears into the wall. Please note the brush will add a certain amount of control to the door through friction. This is normal and aids the reduction of the doors speed to stop it slamming.

Once Brush is in position final decoration or trimming of the opening can then take place. However please ensure that any trim applied directly above the opening should be made removable in case of maintenance requirements in the future.

We recommend that the Closing Jamb be rebated to allow the glass door 2 rest between two solid sections. Rebate would normally be around 10mm but can be made to suit. Just allow for the rebate size in the glass calculations. The Glass Bumper Seal can be placed either on the glass edge ow within rebate.

Section Showing Glass Door Installation

