

Trend

- *aquamac recessor* - *page 156*
- *weatherseal recessor* - *page 156*
- *biscuit cutter* - *page 156*
- *intumescent strip cutter* - *page 157*
- *bookcase cutter* - *page 157*
- *straight flute plunge cutter* - *page 157*
- *trend & snappy products* - *page 158*

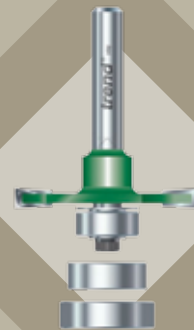

TREND C207X1/2TC Aquamac 21 Recesser

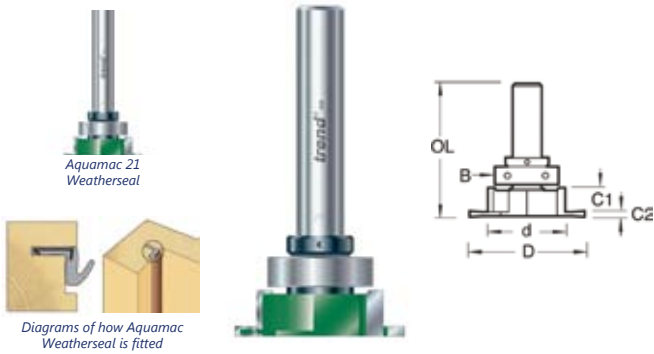

D: 54.5mm
d: 34.3mm
C1: 10.3mm
C2: 2.7mm
B: 28.5mm
OL: 90mm

Comes with guide bearing which reduces setting up time and simplifies machining. Tungsten Carbide tipped.

For use with Aquamac 21 Weatherseal
Bronze 25m - 19007 / Bronze 250m - 19005
White 25m - 19008 / White 250m - 19006

Shank Diameter:

1/2"

Order Code:

26280

TREND C206X1/2TC Aquamac 63 Recesser

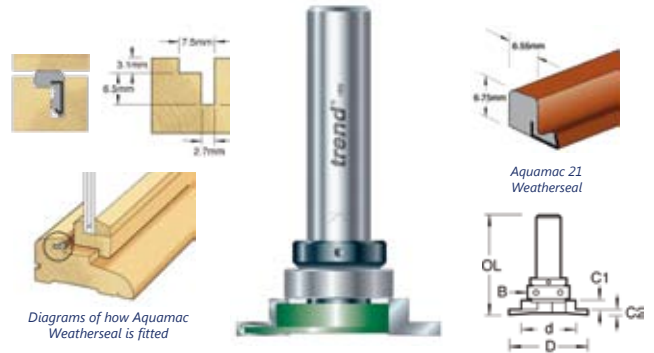

D: 41.3mm
d: 28.3mm
C1: 4.8mm
C2: 2.7mm
B: 22mm
OL: 67mm

Allows for a particularly small gap between sash and frame. The slot can be positioned part way down the side of the rebate, or at the bottom of the rebate. Tungsten Carbide tipped.

For use with Aquamac 63 Weatherseal
Bronze 25m - 19003 / Bronze 300m - 19001
White 25m - 19004 / White 300m - 19002

Shank Diameter:

1/2"

Order Code:

26281

TREND C213X1/2TC Weatherseals Recesser

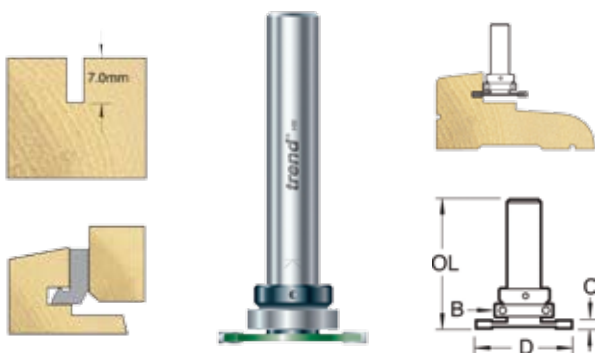

D: 36mm
C: 3mm
OL: 80mm
B: 22mm

Tungsten Carbide tipped.

Shank Diameter:

1/2"

Order Code:

26287

TREND C152X1/2TC Biscuit Cutter

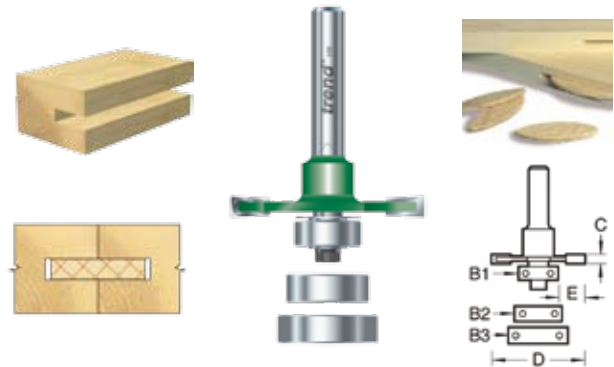

D: 37.2mm
Cut Length: 4mm
B1: 12.7mm
B2: 16.0mm
B3: 19.0mm

Tungsten Carbide tipped.

For use with all biscuits available.
To see what we have in stock please see section K, page 98.

Shank Diameter:

1/2"

Order Code:

26285

TREND C208X1/2TC Intumescent Strip Cutter



Cutter Set: 10mm x 40mm
D: 40mm
C: 10mm
B: 32mm
E: 4mm

Cuts grooves on doors or frames to accept intumescent strips.
Enables the formation of effective barriers to both fire and smoke.
Use of alternative ball bearings diameters other seal thicknesses can be introduced. Tungsten Carbide tipped.

For use with Intumescent Strips
Brown - 19045 / Brown (with brush) - 19047
White - 19046 / White (with brush) - 19048

Shank Diameter:

1/2"

Order Code:

26282

TREND C016X1/4TC Intumescent Strip Cutter

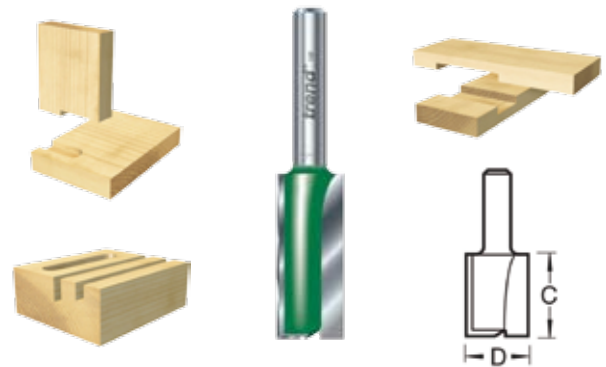

D: 10mm
C: 19.1mm

Tungsten Carbide tipped.

For use with Intumescent Strips
Brown - 19045 / Brown (with brush) - 19047
White - 19046 / White (with brush) - 19048

Shank Diameter:

1/4"

Order Code:

26283

TREND 36/10X1/4TC Bookcase Strip Rebater



D1: 13mm
D2: 19mm
C1: 10mm
C2: 6mm

Allows for a particularly small gap between sash and frame. The slot can be positioned part way down the side of the rebate, or at the bottom of the rebate.
Tungsten Carbide tipped.

For use with Bookcase Strips
Solid Brass 1.8m - 17300 (Studs - 17422) / Electro Brass 1.8m - 17303 (Studs - 17422)
Zinc Plated 1.8m - 17304 (Studs - 17423) / Bronze 1.8m - 17302 (Studs - 17421)

Shank Diameter:

1/4"

Order Code:

26284

TREND C153DX1/2TC Straight Flute Plunge Cutter



D: 12.7mm
C: 50mm

Tungsten carbide cutter with centre tip.

Ideal for plunge cutting i.e. worktops etc.

Shank Diameter:

1/2"

Order Code:

26286

Trend Router Bits

We have an extensive range of router bits and cutters for all your needs.

Whether it's a single cutter you're after for that particular finish for your project or a complete set containing a range of popular cutters for standard jobs, we have the lot.



Router bits come in hundreds of varieties to create either decorative effects or joinery aids so if there is something a bit different you need we are able to order you your cutter, which will be sent next day delivery and direct to your door, so no waiting around to finish your work.

Router Bits can be made to match any imaginable profile which is especially beneficial for home restoration projects when often the trim and moulding of the home is out of production.



Please call in to see us, phone your order through or visit our website to see what solutions we can offer you.

www.marchesironmongery.co.uk

Trend Jigs



At Marches we have a range of Trend jigs available and in stock. A jig is a device used as a holding and guiding mechanism for a router. There is an extensive range of jigs available including Hinge jigs and Worktop jigs.

The Hinge Jig is a portable template set designed for recessing hinges in wooden doors & frames. It is easy to use with minimal setting-up time which aids in completion of the job both accurately & quickly. Can be used on-site & in joinery shops to increase productivity with excellent results.

A worktop jig is designed to enable you to cut precise butt & scribe joints in postform worktops and is constructed from hardwearing solid laminate and comes with manufacturers warranty.



Trend Sharpening Kits



We have a range of sharpening kits from Trend which are specifically designed to care for your router bits and to keep them producing exceptional results time after time. They can also be used to sharpen planers, chisels and turning tools.

Trend Spindle Blocks/Moulders



We stock a range of Trend spindle moulders and blocks and can provide you with the right tool for your particular job.

A spindle moulder is a stationary woodworking machine in which a spindle spins at moderately high speeds. Specially shaped bits are mounted on the spindle. As the workpiece is fed into the machine, the bit cuts a profile into it.

On some spindle moulders, router bits can also be used using a special mounting adapter. The machine normally features a vertical fence, against which the workpiece is guided to control the horizontal depth of cut.

Spindle moulders do essentially the same job as the router table, with the main difference being that a wood shaper is a stationary machine designed for larger volume work while a router is a hand tool for lighter duty work.

We also stock a selection of profile cutters and limiters to go with the spindle moulders, please get in touch for advice or to talk your requirements through.



Snappy Accessories



We stock and have access to an extensive range of Snappy tools, accessories and kits from one of the countries biggest names.

You can buy single items to add to your existing Snappy tools selection like holesaws, quick release drill bits for wood and masonry, pozi and phillips drill bits to mention but a few.

You can also get hold of a number of Snappy kits and sets which come complete with every possible combination of bits, tools, guides and marking tools.

Snappy are a world renowned company who produce quality tools and accessories for every possible job you could think of and possibly a few you haven't thought of!

Please call in to see us, phone your order through or visit our website to see what solutions we can offer you.

www.marchesironmongery.co.uk



Snappy